

TECHNICAL MANUAL

**OPERATOR'S, UNIT AND
DIRECT SUPPORT
MAINTENANCE MANUAL
(INCLUDING REPAIR PARTS
AND SPECIAL TOOLS LIST)**

**FILTER/SEPARATOR,
LIQUID FUEL, FRAME
MOUNTED,
600 GPM CAPACITY
MODEL GFS-30-V-600
NSN 4330-00-522-1850**

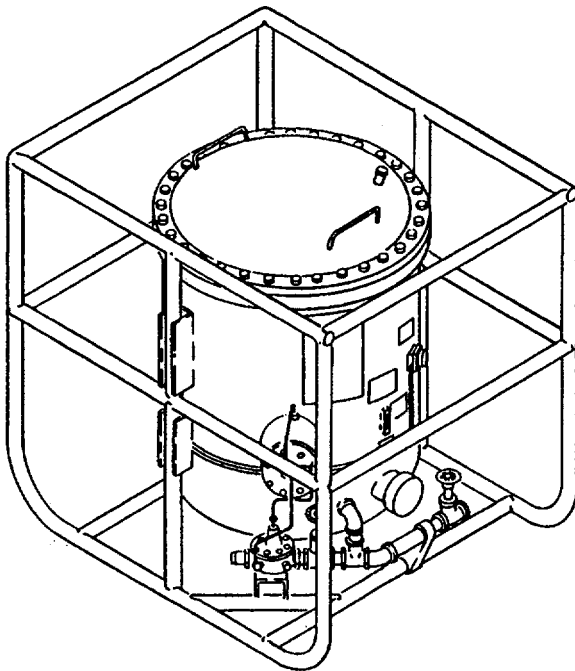

**Equipment Description
and Data
Page 1-3**

**Operating Instructions
Page 2-1**

**Operator's Controls
and Indicators
Page 2-1**

**Operator Troubleshooting
Page 3-1**

**Unit Troubleshooting
Page 4-5**

**Unit Maintenance
Page 4-7**

Approved for public release; Distribution is unlimited.

* This manual supersedes TM 5-4330-234-1 3&P, dated 4 September 1984.

**HEADQUARTERS, DEPARTMENT OF THE ARMY
23 May 1991**

WARNING

Take particular heed to specific WARNINGS and CAUTIONS throughout this manual.

Dry cleaning solvent, PD-680, used to clean parts is potentially dangerous to personnel and property. Avoid repeated or prolonged skin contact. Do not use near open flame or excessive heat. Flash point of solvent is 100 - 138°F (38 - 60°C).

Do not smoke or use open flame in vicinity of filter/separator. Use protective equipment to prevent skin and eye contact with fuel.

Make sure fire extinguishers and fire fighting equipment are available in the immediate area. Be extremely careful when using a carbon Tetrachloride fire extinguisher in an enclosed area. Provide adequate ventilation.

Do not drain fuel from the unit on the ground. Drain fuel into a container that can be closed, otherwise fire hazard or environmental contamination could result.

Use protective equipment to prevent skin and eye contact with fuel.

Use rubber fuel resistant gloves when replacing filter elements due to toxic effects of some fuel additives.

Dispose of filter elements in accordance with local policy.

Do not operate the filter/separator unit until it has been connected to suitable ground. A static discharge could ignite the fuel or cause an explosion of the fuel vapor.

Use a lifting device with a lifting capacity of at least one ton. Do not allow unit to swing back and forth while hanging in the air. If you fail to heed this warning, serious injury or death may occur to personnel or, the equipment may be damaged.

For artificial respiration, refer to FM 21 -1 1.

a/(b blank)

TECHNICAL MANUAL

No. 10-4330-234-13&P

HEADQUARTERS
DEPARTMENT OF THE ARMY
WASHINGTON, D.C., 23 May 1991

**Operator's, Unit and Direct Support Maintenance Manual
(including Repair Parts and Special Tools List)
for**

**FILTER SEPARATOR, LIQUID FUEL, FRAME MOUNTED, 600 GPM CAPACITY
MODEL GFS-30-V600
NSN 4330-00-522-1850**

REPORTING ERRORS AND RECOMMENDING IMPROVEMENTS

You can help improve this manual. If you find any mistakes or if you know of a way to improve the procedures, please let us know. Mail your letter, DA Form 2028 (Recommended Changes to Publications and Blank Forms), or DA Form 2028-2 located in the back of this manual directly to: US Army Troop Support Command, ATTN: AMSTR-MCTS, 4300 Goodfellow Blvd., St. Louis, Mo 63120-1798. A reply will be furnished to you.

Approved for public release; Distribution is unlimited.

TABLE OF CONTENTS

		Page	Illus Figure
CHAPTER 1.	INTRODUCTION		
	OVERVIEW	1-1	
Section I.	General	1-1	
Section II.	Equipment Description and Data	1-2	
Section III.	Technical Principles of Operation	1-5	
CHAPTER 2.	OPERATING INSTRUCTIONS	2-1	
	OVERVIEW	1-1	
Section I.	Operator's Controls and Indicators	2-1	
Section II.	Operator Preventive Maintenance Checks and Services (PMCS)	2-3	
Section III.	Operation Under Usual Conditions	2-6	
Section IV.	Operation Under Unusual Conditions	2-10	
CHAPTER 3 .	OPERATOR'S MAINTENANCE INSTRUCTIONS		
	OVERVIEW	3-1	
Section I.	Lubrication Instructions	3-1	
Section II.	Operator Troubleshooting Procedures	3-1	
Section III.	Operator's Maintenance Procedures	3-3	

*This manual supersedes TM 5-4330-234-13&P, dated 4 September 1984.

TABLE OF CONTENTS (cont)

	Page	Illust/ Figure
CHAPTER 4. UNIT MAINTENANCE OVERVIEW	4-1	
Section I. Repair Parts; Special Tools; and Support Equipment	4-1	
Section II. Service Upon Receipt	4-1	
Section III. Unit Preventive Maintenance Checks and Services (PMCS)	4-4	
Section IV. Unit Troubleshooting	4-5	
Section V. Unit Maintenance Procedures	4-7	
Section VI. Preparation for Shipment or Storage	4-32	
CHAPTER 5. DIRECT SUPPORT MAINTENANCE	5-1	
APPENDIX A REFERENCES	A-1	
APPENDIX B MAINTENANCE ALLOCATION CHART	B-1	
APPENDIX C COMPONENTS OF END ITEM AND BASIC ISSUE ITEMS	C-1	
APPENDIX D ADDITIONAL AUTHORIZATION LIST	D-1	
APPENDIX E EXPENDABLE/DURABLE SUPPLIES AND MATERIALS LIST	E-1	
APPENDIX F REPAIR PARTS AND SPECIAL TOOLS LIST	F-1	
Section I. Introduction	F-1	
Section II. Repair Parts List	F-1	
Group 00. Filter/Separator		
Filter Separator Identification and Instruction Plates	F-11	1
Group 01. Cover, Assembly	F-13	2
Group 02. Canister, Clamp Band, Filter Element	F-15	3
Group 03. Gages, Mounting Lines and Fittings	F-17	
Differential Pressure Gage	F-17	4
Sight Gage	F-19	5
Group 04. Valves and Lines	F-21	
Pressure Relief Valve	F-21	6
Manual Drain/isolation Valve	F-23	7
Automatic Drain Valve	F-25	8
Float Control Valve	F-27	9
Group 05. Ground Assembly	F-29	10
Ground Rods	F-29	10
Group 06. Frame Assembly (Not Applicable)		
Section III. Special Tools List (Not Applicable)		
Section IV. Cross-Reference Indexes		
National Stock Number Index	F-33	
Part Number Index	F-34	
Figure and Item Number Index	F-37	
INDEX	Index 1	

LIST OF ILLUSTRATIONS

Figure Number	Title	Page
1-1	Filter/Separator, Liquid Fuel, Frame Mounted, 600 GPM Capacity	1-0
1-2	Location and Description of Major Components	1-4
2-1	Operator's Controls and Indicators	2-2
2-2	Starting the Filter/Separator	2-7
2-3	Operating the Filter/Separator	2-8
2-4	Stopping the Filter/Separator	2-9
4-1	Installing Filter/Separator	4-3
4-2	Typical Operational Layout	4-3
4-3	Cover Assembly, Replace	4-9
4-4	Cover Assembly, Repair	4-9
4-5	Clamp Band, Replace	4-10
4-6	Filter Canister and Element, Removal and Installation	4-12
4-7	Differential Pressure Gage, Replace	4-13
4-8	Differential Pressure Gage Lines, Repair	4-15
4-9	Sight Gage, Replace	4-16
4-10	Pressure Relief Valve, Replace	4-17
4-11	Manual Drain Valve, Replace	4-19
4-12	Manual Drain Valve, Repair	4-21
4-13	Automatic Drain Valve, Replace	4-23
4-14	Automatic Drain Valve, Repair	4-25
4-15	Float Control, Replace	4-27
4-16	Float Control, Repair	4-29
4-17	Grounding Assembly, Replace	4-30
4-18	Grounding Assembly, Repair	4-31

LIST OF TABLES

Table Number	Title	Page
2-1	Operator Preventive Maintenance Checks and Services (PMCS)	2-3
3-1	Operator Troubleshooting Procedures	3-2
4-1	Unit Preventive Maintenance Checks and Services (PMCS)	4-4
4-2	Unit Troubleshooting Procedures	4-5

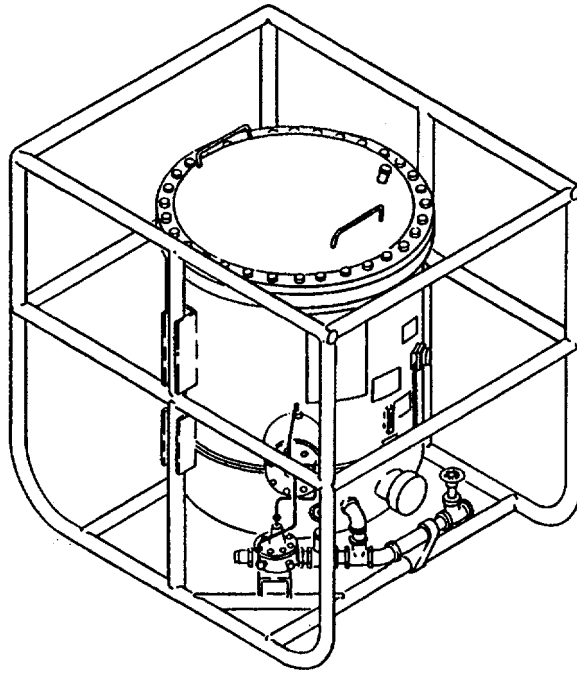

Figure 1-1. Filter/Separator, Liquid Fuel, Frame Mounted 600 GPM Capacity.

CHAPTER 1

INTRODUCTION

		Page
	OVERVIEW	1-1
Section I.	General.....	1-1
Section II.	Equipment Description and Data	1-2
Section iii.	Technical Principles of Operation.....	1-5

OVERVIEW

This chapter includes general information regarding the filter/separator as well as specific information pertinent to equipment description and data and technical principles of operation.

SECTION I. GENERAL

Paragraph		Page
1-1	Scope	1-1
1-2	Maintenance Forms, Records and Reports.....	1-1
1-3	Reporting Equipment Improvement Recommendations.....	1-2
1-4	Destruction of Army Materiel to Prevent Enemy Use.....	1-2
1-5	Preparation for Storage or Shipment	1-2
1-6	Hand Receipt Manual.....	1-2

1-1. **Scope.** The scope of this manual is described in the following subparagraphs.

a. Type of Manual. This manual provides operator and unit maintenance instructions for Filter/Separator, Liquid Fuel, Frame Mounted, 600 GPM Capacity NSN 4330-00-522-1850 model GFS-30-V-600 (figure 1-1). This manual also provides a Repair Parts and Special Tools List located at Appendix F.

b. Equipment Name. 600 GPM Capacity Frame Mounted Liquid Fuel Filter/Separator, hereinafter, referred to as the filter/separator.

c. Purpose of Equipment. The filter/separator is a static device which is installed in a fuel system. The filter/separator is capable of removing entrapped water and solid contaminants from fuel.

1-2. **Maintenance Forms, Records and Reports.**

a. Reports of Maintenance and Unsatisfactory Equipment. Department of the Army forms and procedures used for equipment maintenance will be those prescribed by DA Pam 738-750, as contained in The Army Maintenance Management System.

b. Reporting of Item and Packaging Discrepancies. Fill out and forward SF 364 (Report of Discrepancy (ROD)) as prescribed in AR 735-11 -2.

1-3. **Reporting of Equipment Improvement Recommendations (EIR).** If your filter/separator needs improvement, let us know. Send us an EIR. You, the user, are the only one who can tell us what you don't like about your equipment. Let us know why you don't like the design or performance. Put it on an SF 368 (Product Quality Deficiency Report). Mail it to us at: Commander, U.S. Army Troop Support Command, ATTN: AMSTR-QS, 4300 Goodfellow Boulevard, St. Louis, Missouri 63120-1798. We will send you a reply.

1-4. **Destruction of Army Materiel to Prevent Enemy Use.** Refer to TM 750-244-3 for procedures to destroy equipment to prevent enemy use.

1-5. **Preparation for Storage or Shipment.** Refer to Chapter 4, section VI, and AR 750-1 for Administrative Storage.

1-6. **Hand Receipt Manual.** Not applicable.

SECTION II. EQUIPMENT DESCRIPTION AND DATA

Paragraph		Page
1-7	Equipment Characteristics, Capabilities and Features	1-2
1-8	Location and Description of Major Components.....	1-3
1-9	Equipment Data	1-4
1-10	Safety, Care and Handling	1-5

1-7. Equipment Characteristics, Capabilities and Features.

a. Characteristics. The filter/separator is an upright unit made up of an aluminum shell mounted within an aluminum frame. Inlet, outlet, and drain connections are provided. A differential pressure gage, a liquid level gate (sight glass), a pressure relief valve, a float control, and an auto drain are mounted on the tank. Lifting handles are welded to the cover assembly portion of the tank. The handles are used to help in the removing or placing the cover in correct position on the unit.

b. Capabilities and Features.

- (1) Highly portable.
- (2) All weather operational.
- (3) Automatic water drain valve.
- (4) 600 GPM (2271 LPM) rating.

1-8 Location and Description of Major Components. (Figure 1-2)

FILTER/SEPARATOR SHELL (1). Consists of an aluminum shell contained within an aluminum frame.

FILTERING SECTION (2). The center portion of the filter/separator shell contains 30 filter separating devices.

CONTROL FLOAT VALVE (3). This valve contains a float ball. As the water level rises on the deck plate of the filter separator tank, the float ball rises until it reaches an initial predetermined Level. System pressure forces entrapped water out of the tank.

AUTOMATIC WATER DRAIN VALVE (4). This valve will automatically drain when it receives system fluid pressure from the control float valve (3).

PRESSURE RELIEF VALVE (5). This valve is preset at 165 pounds per square inch (psi) (1137.7 kpa). When the internal pressure of the tank exceeds this setting, the valve will open.

SIGHT GAGE (6). The sight gage gives a visual indication of where water and fuel interface.

DIFFERENTIAL PRESSURE GAGE (7). Reads the pressure required to force the fuel through the filter elements.

MANUAL DRAIN GATE VALVE (8). Provides a way of manually draining the filter/separator tank.

DRAIN PLUG (9). A pipe plug connected to the bottom of the unit to allow drainage of fuel and water when necessary.

PRESSURE VENT VALVE (10). A manually operated valve used to depressurize the filter/separator.

ISOLATION DRAIN VALVE (11). Used when isolation of the automatic drain valve is required.

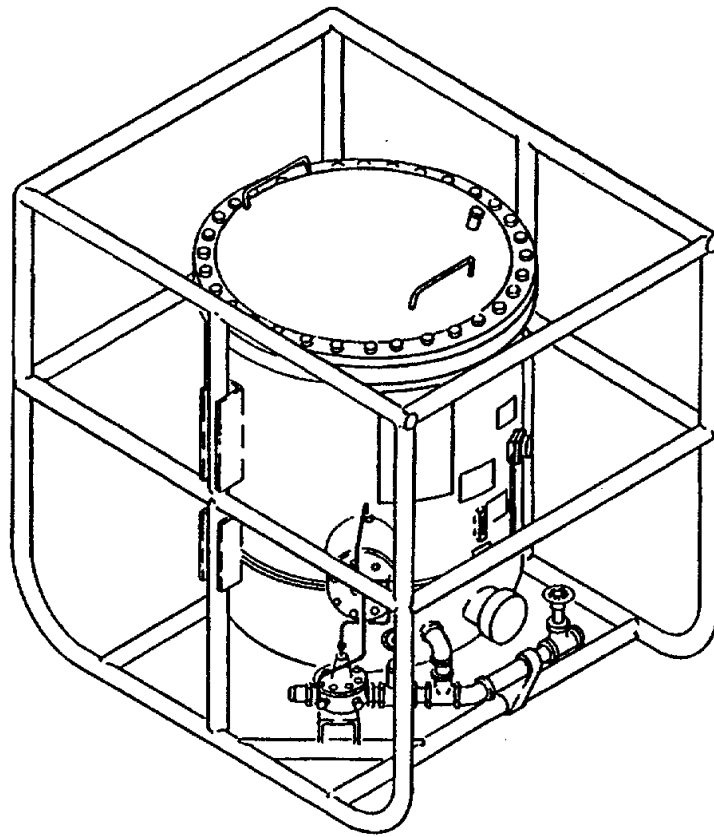

Figure 1-2. Location and Description of Major Components.

1-9. **Equipment Data.**

a. Filter/Separator.

Model.....GFS-30-V-600
 Rating600 GPM (2271 LPM)
 Working Pressure.....150 PSI (1034 KPA)

b. Differential Pressure Gage.

Range0-35 PSI (0.241.3 KPA)
 Fluid Service.....Aviation Gasoline, Motor Gasoline, and Diesel Fuel
 Temperature Rating-25° to 125°F (-31.70 to 51.70C)

c. Automatic Water Drain Valve.

Size.....600 GPM (2271 LPM)
 Pressure Rating.....150-230 PSI (1034-1585.9 KPA)
 Temperature Range0 to 180°F (0° to 82.2°C)

d. Water Level Control Valve.

Rating225 PSI (max.) (1551.4 KPA max.)
 Temperature Range32° to 125°F (0° to 51.7°C)
 Fluid ServiceAviation Gasoline, Motor Gasoline, and Diesel Fuel

e. Dimension and Weight.

Height52 in. (132.1 cm)
 Width45 in. (114.3 cm)
 Length.....52 in. (132.1 cm)
 Weight (dry)600 lb (272.4 kg)
 Shipping Cube (crated).....67 cu ft (1.9 cu m)

1-10. **Safety, Care, and Handling.** Observe all WARNINGS, CAUTIONS, and NOTES in this manual. This equipment can be extremely dangerous if these instructions are not followed.

SECTION III. TECHNICAL PRINCIPLES OF OPERATION

1-11. **Technical Principles of Operation.**

a. General. The filter/separator is a static device which is installed in a fuel system to remove water and solid contaminants from the fuel. The filter/separator is normally installed between the fuel system pump and the fuel dispensing equipment. Thus, fuel is pushed through the filter/separator by pump action.

b. Simplified Principles of Operation. Fuel enters through the inlet connection and passes through the filter center tube and passes towards the outside of the element. Upon reaching the exterior of the element the fuel passes through the layers of plated paper, cotton knit and screen. The water droplets, being heavier than fuel, fall to the bottom of the tank. As water collects in the tank the water level rises. Clean fuel floats on top of this water. The point at which the fuel and water meet is known as the interface. The liquid level gage gives a visual indication of this interface. Automatic controls or manual controls permit the discharge of the separated water and prevents the flow of fuel out of the filter/separator.

CHAPTER 2
OPERATING INSTRUCTIONS

		Page
	OVERVIEW	2-1
Section I.	Operators Controls and Indicators	2-1
Section II.	Operator Preventive Maintenance Checks and Services (PMCS).....	2-3
Section III.	Operation Under Usual Conditions	2-6
Section IV.	Operation Under Unusual Conditions	2-10

OVERVIEW

This chapter covers operator controls and indicators, operator PMCS, and the operation of the filter/separator under usual and unusual conditions.

SECTION I. OPERATOR'S CONTROLS AND INDICATORS

Paragraph		Page
2-1	General	2-1
2-2	Operator's Controls and Indicators	2-1

2-1. **General.** The filter-separator is equipped with two manually operated drain valves, a float control valve, automatic water drain valve, vent pressure valve, differential pressure gage, and a liquid level signal gage.

2-2. **Operator's Controls and Indicators.** Figure 2-1 illustrates the operator's controls and indicators for the filter/separator.

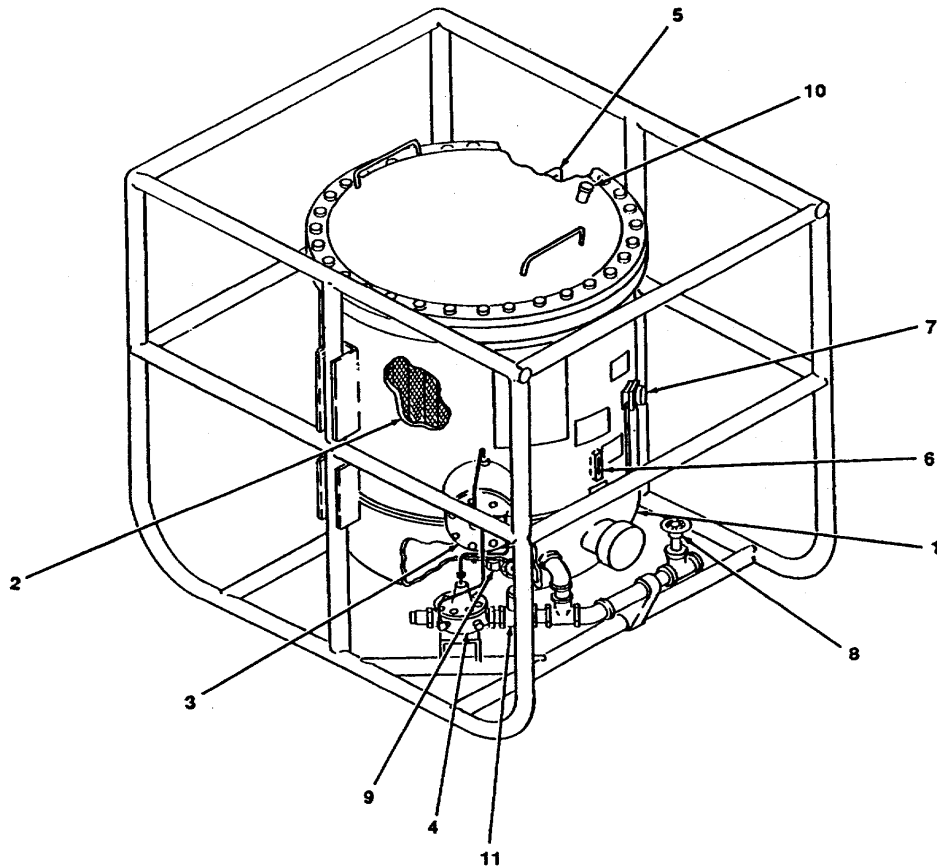

Figure 2-1. Operator's Controls and Indicators.

Key	Control or Indicator	Function
1	Vent Pressure Valve	Manually operated to depressurize the filter/separator.
2	Differential Pressure Gage	Reads the pressure required to force the fuel through the filter elements.
3	Manual Drain Valve	Provides a way to manually drain the filter/separator tank.
4	Automatic Water Drain Valve	Automatically drains when it receives system fluid pressure from the float control valve.
5	Sight Gage	Gives a visual indication of where water and fuel interface.
6	Float Control Valve	As water level rises on the deck plate of the filter/ separator tank, the float bail rises until it reaches a predetermined level. System pressure forces entrapped water out of the tank.

SECTION II. OPERATOR PREVENTIVE MAINTENANCE CHECKS AND SERVICES (PMCS)

Paragraph		Page
2-3	General.....	2-3
2-4	Purpose of PMCS Table	2-3
2-5	Explanation of Columns.....	2-3
2-6	Equipment is Not Ready/Available If Column.....	2-3
2-7	Reporting Deficiencies.....	2-4
2-8	Special Instructions.....	2-4

2-3. **General.** Operator PMCS are performed to ensure that the filter/seperator is ready for operation at all times. Perform the checks and services at the specified intervals.

- a. Before you operate, perform your before (B) PMCS. Observe all CAUTIONS and WARNINGS.
- b. While you operate, perform your during (D) PMCS. Observe all CAUTIONS and WARNINGS.
- c. After you operate, be sure to perform your after (A) PMCS.
- d. If your equipment fails to operate, refer to paragraph 3-3.

2-4. **Purpose of PMCS Table.** The purpose of the PMCS table is to provide a systematic method of inspecting and servicing the equipment. In this way, small defects can be detected early before they become a major problem causing the equipment to fail to complete its mission. The PMCS table is arranged with the individual PMCS procedures listed in sequence under assigned intervals. The most logical time (before, during, or after operation) to perform each procedure determines the interval to which it is assigned. Make a habit of doing the checks in the same order each time and anything wrong will be seen quickly. See paragraphs 2-5 and 2-6 for an explanation of the columns in table 2-1.

2-5. **Explanation of Columns.** The following is a list of the PMCS table column headings with a description of the information found in each column.

- a. Item No. This column shows the sequence in which the checks and services are to be performed, and is used to identify the equipment area on the Equipment Inspection and Maintenance Worksheet, DA Form 2404.
- b. Interval This column shows a dot • when each check is to be done.
- c. Item to be Inspected/Procedures. This column identifies the general area or specific part where the check or service is to be done, and explains how to do them.
- d. Equipment is Not Ready/Available If. See paragraph 2-6.

2-6. **Equipment is Not Ready/Available If.** This column lists conditions that make the equipment unavailable for use because it is unable to perform its mission, or because it would represent a safety hazard. Do not accept or operate equipment with a condition in the "Equipment is Not Ready/Available If" column.

NOTE

The terms ready/available and mission capable refer to the same status: Equipment is on hand and is able to perform its combat mission. Refer to DA Pam 738-750.

2-7. **Reporting Deficiencies.** If any problem with the equipment is discovered during PMCS or while it is being operated that cannot be corrected at the operator/crew maintenance level, it must be reported. Refer to DA Pam 738-750 and report the deficiency using the proper forms.

2-8. **Special Instructions.** Preventive maintenance is not limited to performing the checks and services Listed in the PMCS table.

WARNING

Drycleaning solvent PD-680 used to clean parts is potentially dangerous to personnel and property. Avoid repeated and prolonged skin contact. Do not use near open flame or excessive heat. Flash point of solvent is 100 - 138°F (38 - 60°C).

- a. Keep it clean. Dirt, grease, oil, and debris get in the way and may cover up a serious problem. Clean as you work and as needed. Use drycleaning solvent on all metal surfaces. Use soap and water to clean rubber or plastic material.
- b. Bolts, Nuts, and Screws. Check them all for obvious looseness, missing, bent, or broken condition. You can't try them all with a tool, but look for chipped paint, bare metal, or rust around boltheads. If you find one you think is loose, tighten it, or report it to unit maintenance if you can't tighten it.
- c. Fluid Lines. Look for wear, damage, and leaks. Make sure clamps and fittings are tight. Wet spots and stains around a fitting or connector can mean a leak. If a leak comes from a loose connector, tighten it. If something is broken or worn out, report it to unit maintenance.
- d. Leakage Definitions. It is necessary for you to know how fluid leakage affects the status of your equipment. The following are definitions of the types/classes of leakage you need to know to be able to determine the status of your equipment. Learn and be familiar with them. When in doubt, NOTIFY YOUR SUPERVISOR!

Leakage Definitions:

Class I	Seepage of fluid (as indicated by wetness or discoloration) not great enough to form drops.
Class II	Leakage of fluid great enough to form drops but not enough to cause drops to drip from item being checked/inspected.
Class II	Leakage of fluid great enough to form drops that fall from the item being checked/inspected.

CAUTION

Equipment operation is allowable with minor leakage (Class I or II) of any fluid except fuel. Of course, consideration must be given to the fluid capacity in the item being checked/inspected. When in doubt, notify your supervisor.

When operating with Class I or II leaks, continue to check fluid level more often than required in the PMCS.

Class III leaks should be reported to your supervisor or unit maintenance.

- e. Painting. Touch-up filter/separator as needed. Refer to TM 43-0139 for specific painting procedures.

Table 2- 1. Operator Preventive Maintenance Checks and Services (PMCS).

NOTE

Within designated intervals, these checks are to be performed in the order listed.

If the equipment must be kept in continuous operation, check and service only those items that can be checked and serviced without disturbing the operation. Make the complete checks and services when the equipment can be shut down.

B - Before D - During A - After

Item No.	Interval			Item to be Inspected Procedure	Equipment is Not Ready/Available If
	B	D	A		
1		●		SAFETY RELIEF VALVE Check Safety relief valve operation for clogs.	Safety relief valve inoperative.
2	●	●	●	TANK COVER Check tank cover for missing bolts, washers, nuts, dents, cracks or leaking packing.	Cover is cracked or packing is leaking fuel. Bolts, washers or nuts are missing.
3		●		DIFFERENTIAL PRESSURE GAGE Check differential pressure gage for safe reading (35 PSI). Check for broken glass.	Pressure differential gage is damaged, or reads over 35 PSI.
4	●	●		SIGHT GAGE Check sight gage for broken glass or leaks	Sight gage is broken or leaking

Table 2- 1. Operator Preventive Maintenance Checks and Services (PMCS) (cont).

B - Before D - During A - After

Item No.	Interval			Item to be Inspected Procedure	Equipment is Not Ready/Available If
	B	D	A		
5		●		AUTOMATIC DRAIN VALVE Check automatic drain valve for breaks or cracks.	Tank is cracked or broken.
6	●		●	FILTER/SEPARATOR Check filter/separator for leaks from the tank; breaks or cracks in tank. Check for water in bottom of tank	

SECTION III. OPERATION UNDER USUAL CONDITIONS

Paragraph		Page
2-9	Starting Procedure	2-6
2-10	Operating	2-7
2-11	Stopping Procedure.....	2-8

2-9. **Starting Procedure.** (Figure 2-2)

WARNING

Do not operate the filter/separator unit until it has been connected to a suitable ground. A static discharge could ignite the fuel or cause an explosion of the fuel vapor.

Do not smoke or use open flame in vicinity of filter/separator. Use protective equipment to prevent skin and eye contact with fuel.

Make sure fire extinguishers and fire fighting equipment are available in the immediate area. Be extremely careful when using a fire extinguisher in an enclosed area. Provide adequate ventilation.

- a. Make sure that the manual drain gate valve (1) is closed. Make sure isolation gate valve (6) is open
- b. Be sure the inlet (2) and outlet (3) connections are tight.
- c. Open the vent pressure valve (4) to allow entrapped air to escape.

- d. Start the system pumping unit. Refer to the applicable pumping unit technical manual.
- e. Open inlet side valves slightly to allow the filter/separator (5) to fill slowly with as little pressure as possible.
- f. When the unit is completely filled, fuel will come through the vent pressure valve. Close vent pressure valve. Make a visual inspection of all connections, joints, and piping components for leaks.
- g. Open inlet side valves fully.

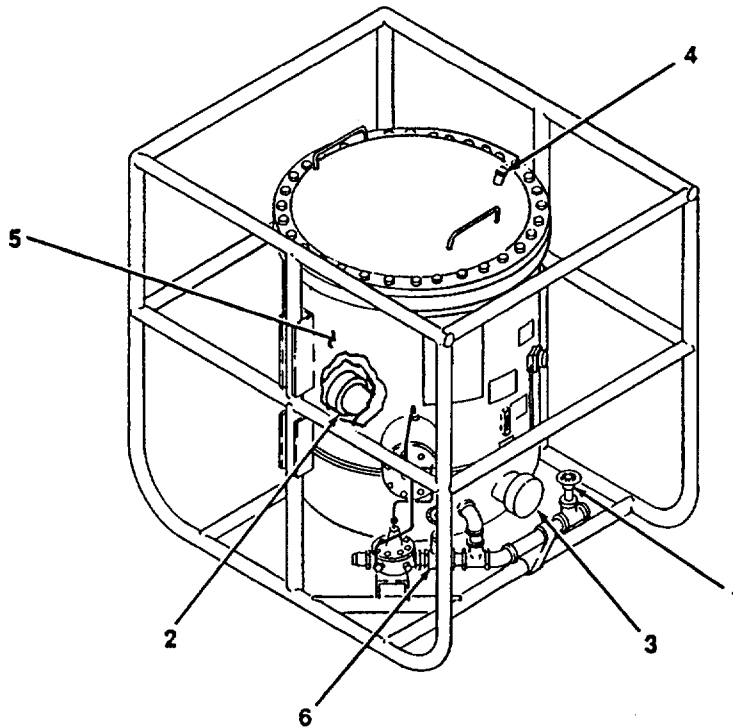

Figure 2-2. Starting the Filter/Separator.

2-10. Operating. (Figure 2-3)

- a. Open outlet side valve(s) to fully opened position.
- b. Observe the differential pressure gage (1). If reading is 0-20 psi (Green) continue operation. If reading is 20-35 psi (Yellow) continue operation and notify unit maintenance upon completion of refueling operation. If reading rises above 35 psi (Red), shutdown operation and notify unit maintenance.
- c. During operation, periodically check the water level sight gage (2) and monitor the opening of the automatic drain valve (3). If the water level reaches the top mark, and the automatic drain valve (3) does not open, open the manual drain valve (4) slightly until ball reaches lower mark, then close valve.
- d. Drain water

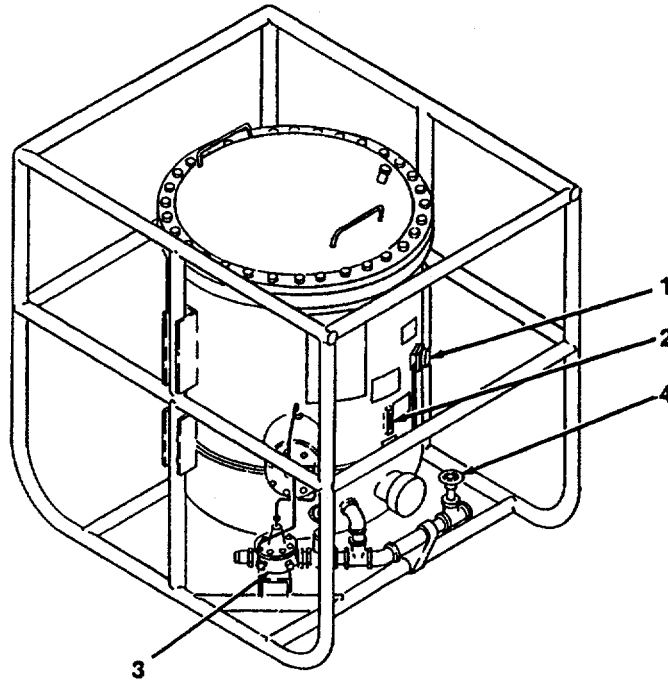

Figure 2-3. Operating the Filter/Separator.

2-11. Stopping Procedure. (Figure 2-4)

- a. Stop the system pumping unit. Refer to the applicable pumping unit technical manual.
- b. Close the inlet side valve(s).
- c. Close the outlet side valve(s).

NOTE

If the filter/separator is not to be in frequent use, drain the tank. Use following instructions.

WARNING

- Do not drain fuel from the unit onto the ground. Drain fuel into a container that can be closed, otherwise fire hazard or environmental contamination could result.
 - Use protective equipment to prevent skin and eye contact with fuel.
 - Stand clear of vent pressure valve when opening.
- d. Open vent pressure valve (1) to depressurize unit.
- e. Open manual drain valve (2).

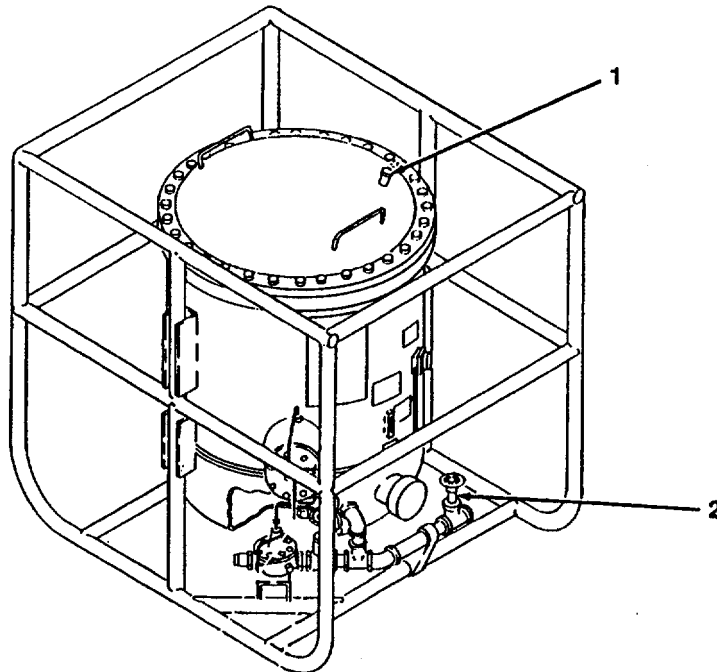

Figure 2-4. Stopping the Filter/Separator.

Section IV. OPERATION UNDER UNUSUAL CONDITIONS

Paragraph		Page
2-12	Operation in Extreme Cold.....	2-10
2-13	Operation in Extreme Heat.....	2-10
2-14	Operation in Dusty or Sandy Areas	2-10
2-15	Operation in Rainy or Humid Conditions	2-10

2-12. Operation in Extreme Cold. The procedures for starting and stopping the filter/separator are the same as under usual conditions except for the following special precautions.

- a. Water must be drained more frequently than usual and at each shut down to avoid freezing.
- b. If possible provide a heated shelter.
- c. Check differential pressure gage regularly to be sure that pressure limits are not being exceeded.

2-13. Operation in Extreme Heat. The procedures for starting and stopping the filter/separator are the same as under usual conditions except for the following special precautions.

- a. Erect a screen or shelter to provide shade.
- b. Check differential pressure gage regularly to be sure that the pressure limits are not being exceeded.
- c. Vent filter/separator when not in operation.

2-14. Operation in Dusty or Sandy Areas. The procedures for starting and stopping the filter/separator are the same as under usual conditions except for the following special precautions:

- a. Select a work site protected by natural barriers or erect screens of dustproof material.
- b. Keep the unit free of dust and dirt, especially when the unit is open for servicing or repair.
- c. Check the differential pressure gage regularly to make sure that pressure limits are not being exceeded.

2-15. Operation in Rainy or Humid Conditions. The procedures for starting and stopping the filter/separator are the same as under usual conditions except for the following special precautions.

- a. Water must be drained through the water drain valve more often than under normal conditions.
- b. Erect a shelter to prevent the entrance of rain into the interior of the unit when it is opened for servicing.
- c. Check differential pressure gage regularly to be sure that pressure limits are not being exceeded.

CHAPTER 3

OPERATOR'S MAINTENANCE INSTRUCTIONS

	Page
OVERVIEW	3-1
Section I. Lubrication Instructions	3-1
Section II. Operator's Troubleshooting	3-1
Section III. Operator's Maintenance Procedures	3-3

OVERVIEW

This chapter contains operator level troubleshooting.

SECTION I. LUBRICATION INSTRUCTIONS

Paragraph	Page
3-1 General	3-1

3-1. **General.** The filter/separator requires no lubrication.

SECTION II. OPERATOR'S TROUBLESHOOTING

Paragraph	Page
3-2 General	3-1
3-3 Operator Troubleshooting Procedures	3-1

3-2. General. This section contains troubleshooting procedures to determine the probable cause of observed equipment malfunctions. Inspections are provided to isolate the faulty component and corrective actions are provided to eliminate the malfunction.

3-3. Operator Troubleshooting Procedures. Refer to symptom index to locate the troubleshooting procedure of the observed malfunction.

- a. Table 3-1 lists the common malfunctions which you may find during operation or maintenance of the filter/separator or its components. You should perform the tests/inspections and corrective actions in the order listed.
- b. This manual cannot list all malfunctions that may occur, nor all test or inspections and corrective actions. If a malfunction is not corrected by listed corrective actions, notify your supervisor.

SYMPTOM INDEX

Symptom	Page
No fuel delivery	3-2
General fuel leakage	3-2
Discharged fuel contains water	3-2
Sudden increase in pressure differential	3-3
Automatic drain valve inoperable.....	3-3

Table 3-1. Operator Troubleshooting Procedures.

MALFUNCTION

TEST OR INSPECTION

CORRECTIVE ACTION

1. NO FUEL DELIVERY.

Step 1. Check to see if outlet side valve is open.

Open valve.

Step 2. Check to see if system pumping unit is operating properly.

Refer to the applicable technical manual.

2. GENERAL FUEL LEAKAGE.

Step 1. Check lines and fittings and seals/gaskets.

If they are damaged, notify unit maintenance.

Step 2. Check for cracks or breaks in tank or components.

If cracks or breaks are present, notify unit maintenance.

3. DISCHARGED FUEL IS CONTAMINATED.

Step 1. Check for high water level.

Drain if water level is high.

Step 2. Check differential pressure gage to see if needle is in the RED area.

If needle is in the red area, notify unit maintenance.

Table 3-1. Operator Troubleshooting Procedures (Cont).

MALFUNCTION	TEST OR INSPECTION	CORRECTIVE ACTION
3.	DISCHARGED FUEL IS CONTAMINATED (Cont).	<p>Step 3. Contamination still exists.</p> <p>Notify unit maintenance.</p>
4.	SUDDEN INCREASE/DECREASE IN PRESSURE DIFFERENTIAL GAGE.	<p>Check to see if pump is operating properly.</p> <p>If pump is not operating properly, refer to applicable technical manual.</p> <p>If problem still exists, notify unit maintenance.</p>
5.	AUTOMATIC DRAIN VALVE INOPERABLE.	<p>Step 1. Check sight gage for water.</p> <p>Check isolation valve to ensure it is open (refer to para. 2-10c.). If opened, manually drain and notify unit maintenance.</p> <p>Step 2. Check for fuel being discharged from automatic drain valve.</p> <p>Close isolation valve, manually drain as needed (refer to para. 2-10c.) and notify unit maintenance.</p>

SECTION III. OPERATOR'S MAINTENANCE PROCEDURES

Paragraph		Page
3-4	General	3-3
3-4.	General. The filter/separator requires no operator level maintenance.	

3-3/(3-4 blank)

CHAPTER 4
UNIT MAINTENANCE

		Page
	OVERVIEW	4-1
Section I.	Repair Parts; Special Tools; and Support Equipment.....	4-1
Section II.	Service Upon Receipt.....	4-1
Section III.	Unit Preventive Maintenance Checks and Services (PMCS).....	4-4
Section IV.	Unit Troubleshooting.....	4-5
Section V.	Unit Maintenance Instructions.....	4-7
Section VI.	Preparation for Shipment or Storage.....	4-32

OVERVIEW

This chapter contains those maintenance instructions that unit level maintenance is authorized to perform.

SECTION I. REPAIR PARTS, SPECIAL TOOLS, AND SUPPORT EQUIPMENT

		Page
4-1	Common Tools and Test Equipment.....	4-1
4-2	Special Tools, and Support Equipment	4-1
4-3	Repair Parts	4-1

4-1. Common Tools and Test Equipment. For authorized common tools and equipment, refer to the Modified Table of Organization and Equipment (MTOE) applicable for your unit.

4-2. Special Tools and Support Equipment. For a listing of special tools and support equipment authorized for use on this equipment, refer to the Repair Parts and Special Tools List, Appendix F, and the maintenance allocation chart (MAC), Appendix B of this manual.

4-3. Repair Parts. Repair parts are listed and illustrated in the Repair Parts and Special Tools List, Appendix F.

SECTION II. SERVICE UPON RECEIPT

		Page
4-4	Unloading	4-2
4-5	Unpacking	4-2
4-6	Inspection	4-2
4-7	Installation	4-2

WARNING

Use a lifting device with a lifting capacity of at least one ton. Do not allow unit to swing back and forth while hanging in the air. If you fail to heed this warning, serious injury or death may occur to personnel or the equipment may be damaged.

4-4. Unloading.

- a. When the filter/separator is received in a crated condition, unload it as near as possible to its operating or storage site.
- b. Use a lifting sling attached to a hoist or crane and lift the crate from the carrier.

4-5. Unpacking.

- a. Dismantle the crate, removing top, sides, and ends from the skid base.
- b. Remove all tie downs and blocking that secure the filter/separator to the skid base.
- c. Use lifting device to lift the unit from the skid base and place it in position.

4-6. Inspection. Make a general visual inspection of the unit to insure that it is complete. Make sure that no physical damage has been done during shipment.

4-7. Installation. (Figure 4-1, Figure 4-2)

- a. This unit will usually be installed in a pipeline, therefore it's installation will be of a more or less permanent nature.
- b. The filter/separator must be placed at a level site in an upright position.
- c. Drive ground rod (1) into earth at least 8 feet deep, and fasten ground cable to the ground rod.
- d. Connect inlet hose from fuel system to inlet connection (2) on the filter/separator. Connect outlet hose to outlet connection (3).

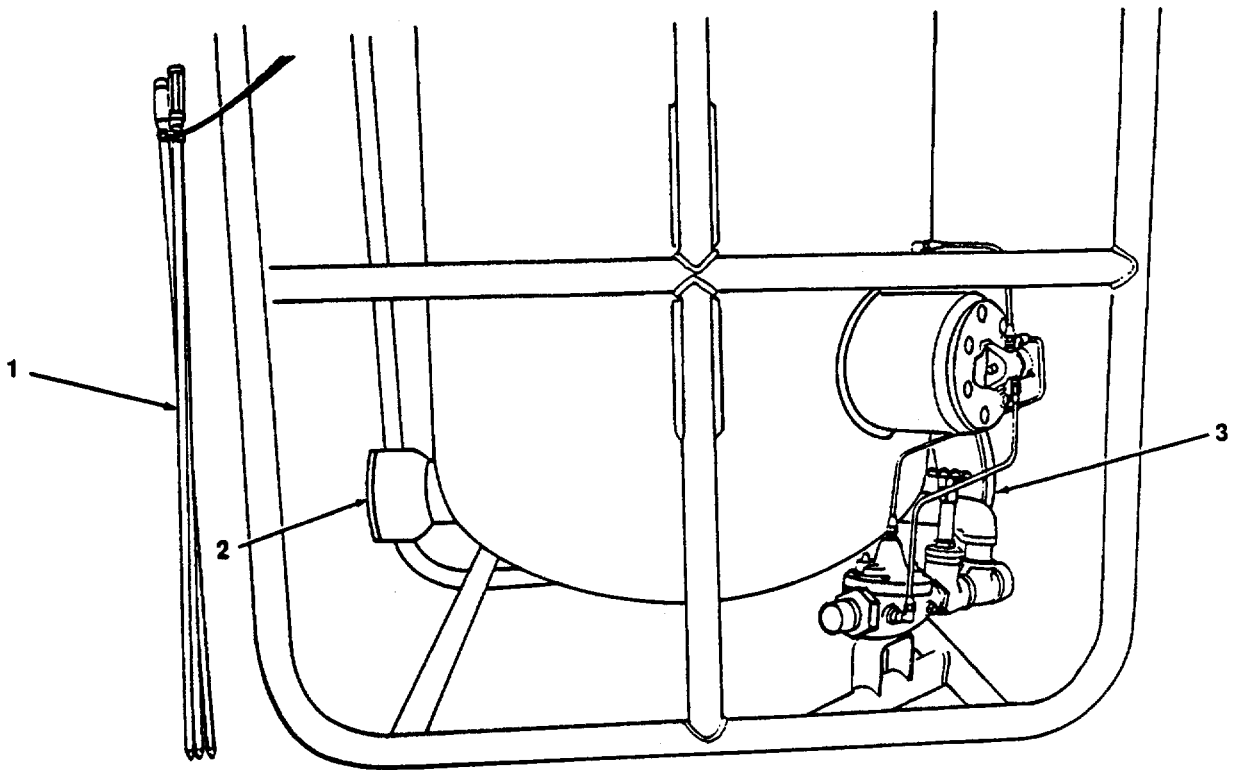

Figure 4-1. Installing Filter/Separator.

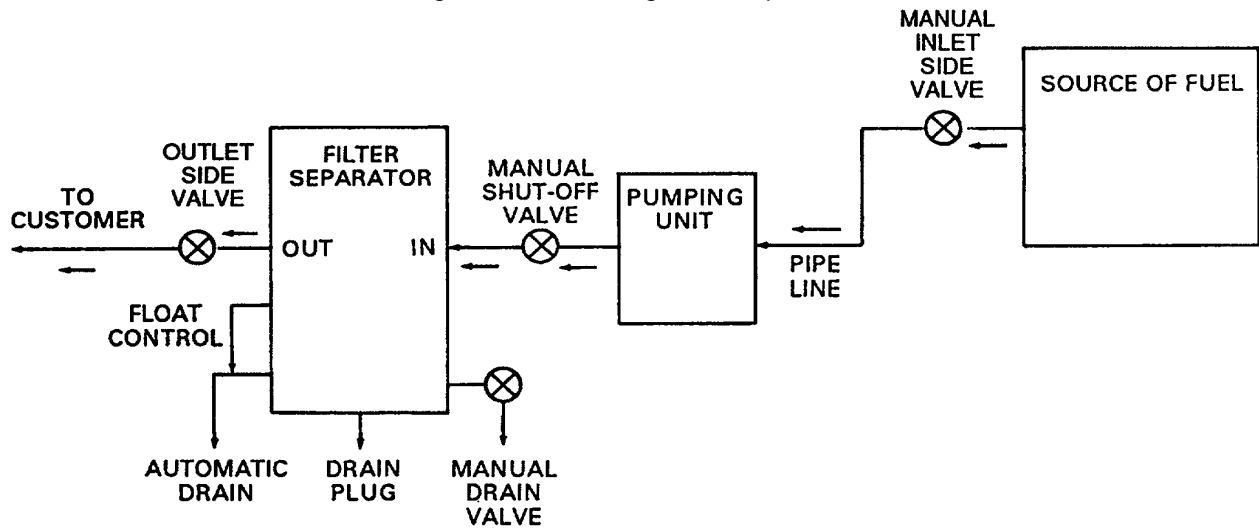

Figure 4-2. Typical Operational Layout.

SECTION III. UNIT PREVENTIVE MAINTENANCE CHECKS AND SERVICES (PMCS)

Paragraph		Page
4-8	General	4-4
4-9	PMCS Procedures.....	4-4

4-8. General. Unit level maintenance PMCS are done to ensure that the filter/separator is in operating condition. A comprehensive PMCS program reduces equipment downtime and increases the operational readiness of the filter/separator.

4-9. PMCS Procedures. Unit level PMCS is contained in table 4-1. The numbers in the Item No. column show the order in which the check or service should be done. These numbers should be used when recording deficiencies and shortcomings on DA Form 2404. Equipment inspection and Maintenance Worksheet. The • in the interval column indicates when a check or service should be done, as follows:

Table 4-1. Unit Preventive Maintenance Checks and Services (PMCS).

M - Monthly

Item No.	Interval	Item to be Inspected	Procedures	Equipment is not Ready/Available If:
	M			
1	•	Clamp Band	Remove tank cover (para. 4-12). Inspect for cracks, breaks and other damage. If any damage exists replace clamp band (para 4-13).	Clamp band is damaged.
2	•	Pressure Relief Valve	Inspect for cracks, breaks and any other damage.	Pressure relief valve is damaged.
3	•	Manual Drain Valve	Inspect for cracks, breaks or other damage	Manual drain valve is damaged.
4	•	Automatic Drain Valve	Inspect for cracks, breaks or other damage	Automatic drain valve is inoperable.

SECTION IV. UNIT TROUBLESHOOTING

Paragraph		Page
4-10	General	4-5
4-11	Unit Troubleshooting Procedures	4-5

4-10. General. This section contains troubleshooting procedures to determine the probable cause of observed equipment malfunctions. Test or inspections are provided to isolate the faulty component and corrective actions are provided to eliminate the malfunction.

4-11. Unit Troubleshooting Procedures. Refer to the symptom index to locate the troubleshooting procedure for the observed malfunction. The table lists the common malfunctions that may occur during the operation or maintenance of the filter/separator. Perform the tests or inspections, and the recommended corrective action in the order listed in the troubleshooting table. If the malfunction is corrected by a specific corrective action, do not continue with the remaining steps, if any, of the troubleshooting procedure. If the malfunction is not corrected by the listed corrective actions notify your supervisor.

SYMPTOM INDEX

Symptom	Page
Contaminated fuel at nozzle	4-5
No fuel delivery	4-5
General fuel leakage	4-6
Sudden increase in pressure differential	4-6
Sudden decrease in pressure differential	4-6

Table 4-2. Unit Troubleshooting Procedures.

MALFUNCTION

TEST OR INSPECTION

CORRECTIVE ACTION

1. CONTAMINATED FUEL AT NOZZLE.

Remove unit cover and inspect canister and filter elements for damage (para. 4-14).

Replace filter elements. (para. 4-14.)

2. NO FUEL DELIVERY.

Step 1. Check to see if pumping unit is operating properly.

If pump is not operating properly, refer to applicable technical manual.

Step 2. Check to see if inlet and outlet valves of filter/separator are open.

Open valves.

Table 4-2. Unit Troubleshooting Procedures (Cont).

MALFUNCTION	TEST OR INSPECTION	CORRECTIVE ACTION
3.	GENERAL FUEL LEAKAGE.	<p>Step 1. Check gaskets and/or seals. Replace if damaged.</p> <p>Step 2. Check lines and fittings for tightness. Tighten lines and fittings or replace as needed. (Refer to paras. 4-15, 4-18, 4-19 and 4-20 as applicable.)</p> <p>Step 3. Check for cracks or breaks in tank shell. Notify direct support maintenance.</p>
4.	SUDDEN INCREASE IN PRESSURE DIFFERENTIAL.	<p>Check differential pressure gage lines for clogs (para. 4-15). Unclog lines. Replace filter elements (para. 4-14). Replace differential pressure gage (para. 4-15).</p>
5.	SUDDEN DECREASE IN PRESSURE DIFFERENTIAL.	<p>Step 1. Check for damaged differential pressure gage lines. Replace damaged lines (para. 4-15).</p> <p>Step 2. Check for damaged filters. Replace filter (para. 4-14).</p> <p>Step 3. Check for defective gage. Replace gage (para. 4-15).</p>

SECTION V. UNIT MAINTENANCE INSTRUCTIONS

Paragraph		Page
4-12	Cover Assembly	4-8
4-13	Clamp Band.....	4-10
4-14	Filter Canister and Element	4-11
4-15	Differential Pressure Gage.....	4-13
4-16	Sight Gage	4-16
4-17	Pressure Relief Valve	4-17
4-18	Manual Drain/Isolation Valve, Lines and Fittings.....	4-18
4-19	Automatic Drain Valve	4-22
4-20	Float Control.....	4-27
4-21	Grounding Assembly.....	4-30

4-12. Cover Assembly

This task covers:

a. Removal

b. Repair

d. Installation

INITIAL SETUP:

Tools:

General Mechanic's Tool Kit (Item 1, Appendix B)

Materials/Parts:

Packing (Appendix F)
Silicone Compound (Item 2, Appendix E)

Personnel Required:

Two

Equipment Condition:

System shutdown (para. 2-11).

LOCATION	ITEM	ACTION	REMARKS
----------	------	--------	---------

WARNING

Do not smoke or use open flame in vicinity of filter/separator. Use protective equipment to prevent skin and eye contact with fuel.

a. Removal. (figure 4-3)

- (1) Remove 30 nuts (1), lockwashers (2), bolts (3) and washers (4).

WARNING

To avoid injury, two persons are required to lift the cover from the tank.

- (2) Remove cover (5) from tank (6).

b. Repair. (figure4-4)

- (1) Unscrew and remove vent pressure valve (1).
- (2) Remove packing (2).
- (3) Inspect all items and replace items that are worn or damaged.
- (4) Coat packing (2) with silicone and install on cover (3).
- (5) Coat threads of vent pressure valve (1) with silicone compound and install on cover (3).

c. Installation. (figure 4-3)

Install cover (5), washers (4), bolts (3), lockwashers (2), and nuts (1) onto tank (6).

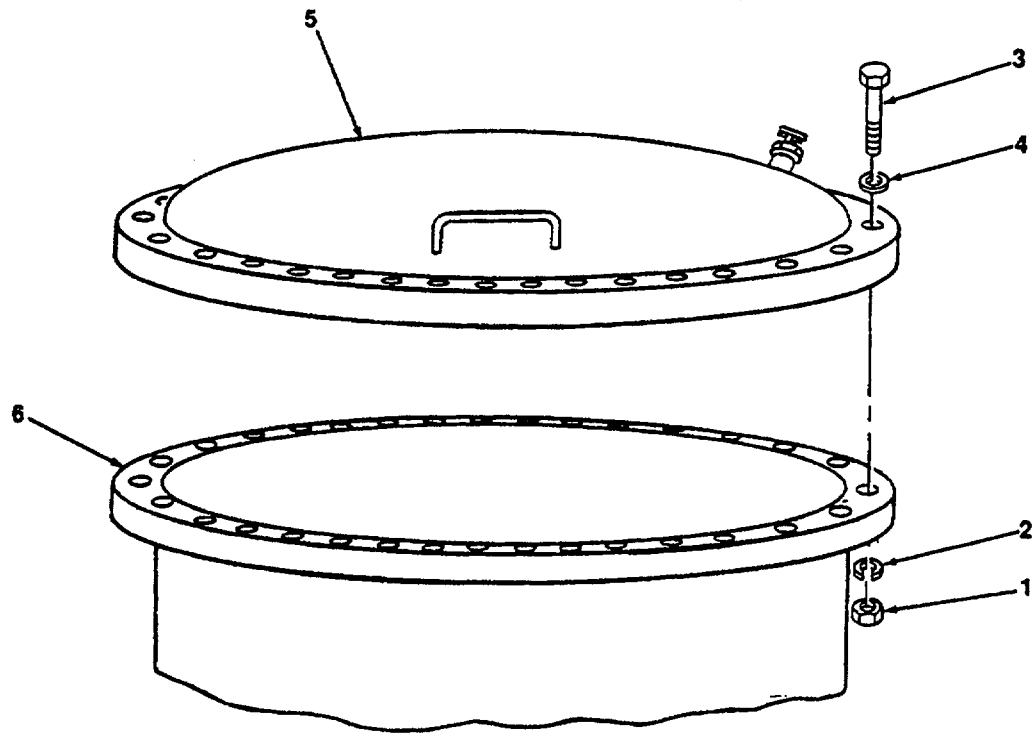

Figure 4-3. Cover Assembly, Replace

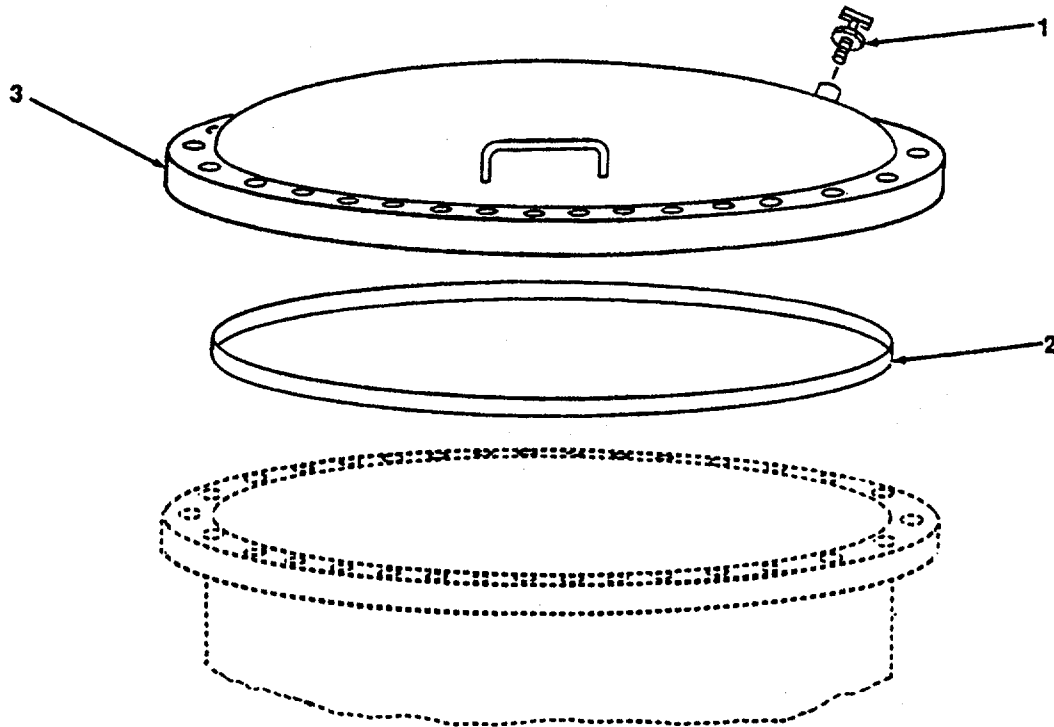

Figure 4-4. Cover Assembly, Repair.

4-13. Clamp Band

This task covers:**Replace**

INITIAL SETUP:

*Equipment Condition:*Cover Removed (para. 4-12)

Replace.

- (1) Loosen thumb screw (1) and remove clamp band (2) from canisters (3).

CAUTION

Ensure clamp band is installed on canister heads to prevent damage to screen.

- (2) Inspect clamp band (2) for cracks or broken thumb screw.
- (3) Place clamp band (2) around canisters (3) and tighten thumb screw (1).

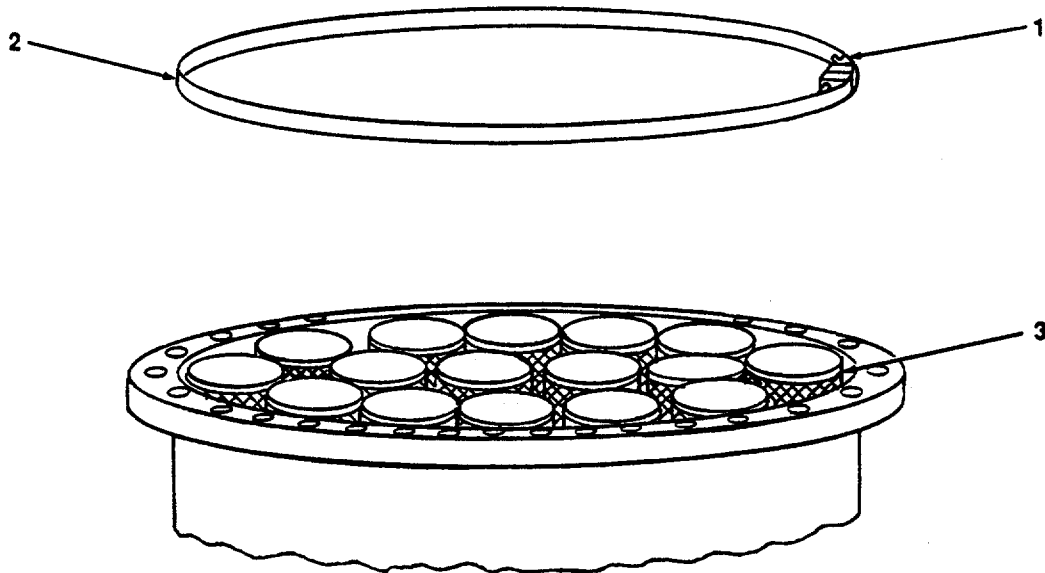

Figure 4-5. Clamp Band, Replace.

FOLLOW-ON MAINTENANCE:

Install cover (para 4-12).

4-14. Filter Canister and Element.

This task covers:**a. Removal****b. Repair****c. Installation**

INITIAL SETUP:

Tools:

Wrench, Spanner (Item 2, Appendix C)

*Equipment Condition:*Cover assembly removed (para. 4-12).
Clamp band, removed (para. 4-13).*Materials/Parts:*Gloves (Item 6, Appendix E)
Cloth, Wiping (Item 3, Appendix E)
Dry Cleaning Solvent (Item 4, Appendix E)
Goggles, Safety (Item 5, Appendix E)

a. Removal. (figure 4-6)

WARNING

The toxic effects of some fuel additives are potentially dangerous to personnel and property. Avoid repeated or prolonged skin contact. Use rubber fuel resistant gloves when replacing elements.

NOTE

Typical procedure given. Procedure is the same for each canister and filter. Change all filters.

- (1) Insert spanner wrench (1) into two holes (2) on top of canister (3).
- (2) Turn spanner wrench (1) 1/4 turn counterclockwise.
- (3) Lift canister (3) out of tank (4).
- (4) Inspect filter element(s) (5) for dirt build-up.
- (5) Discard dirty filter element.

b. Cleaning. (figure 4-6)

WARNING

Drycleaning solvent PD-680 used to clean parts is potentially dangerous to personnel and property. Avoid repeated and prolonged skin contact. Do not use near open flame or excessive heat. Flash point of solvent is 100-138°F (38-60°C).

Clean canister (3) with cleaning solvent PD-680.

4-14. Filter Canister and Element (Cont).

c. Installation. (figure 4-6)

- (1) Insert new filter element (5) in place.
- (2) Place canister (3) or filter element in tank (4).
- (3) Turn canister (3) 1/4 turn clockwise.

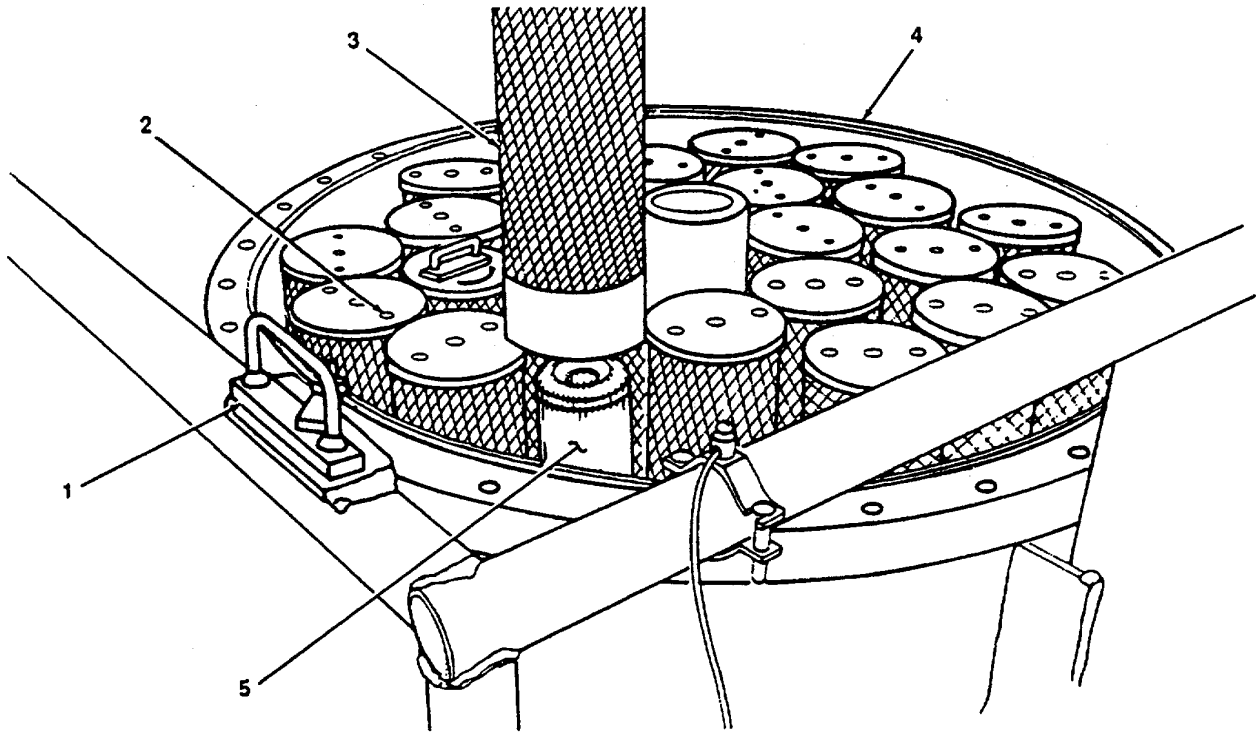

Figure 4-6. Filter Canister and Element, Removal and Installation.

FOLLOW-ON MAINTENANCE:
Install clamp band (para. 4-13).
Install cover assembly (para. 4-12).

4-15. Differential Pressure Gage.

This task covers:**a. Replace****b. Repair**

INITIAL SETUP:*Tools:*

General Mechanic's Tool Kit (Item 1, Appendix B)

Equipment Condition:

Filter/separator shut down (para. 2-11).

*Materials/Parts:*Seating Compound (Item 1, Appendix E)

a. Replace. (figure 4-7)

- (1) Remove fittings (1) from elbows (2).
- (2) Remove two screws (3) and lockwashers (4) and remove differential pressure gage (5).
- (3) Remove elbows (2) from differential pressure gage (5).
- (4) Install elbows (2) into differential pressure gage (5).
- (5) Connect fittings (1) to elbows (2).
- (6) Install differential pressure gage (5) with two washers (4) and screws (3).

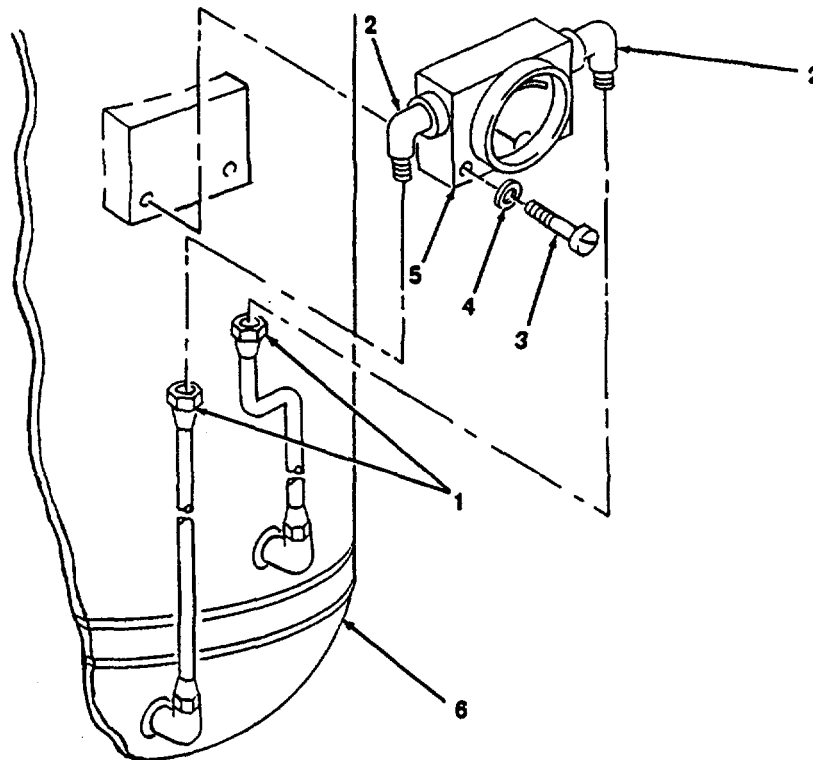
*Figure 4-7. Differential Pressure Gage, Replace.*

4-15. Differential Pressure Gage (Cont).

- b. *Repair.* (figure 4-8)

WARNING

Do not smoke or use open flame in vicinity of filter/separator.

NOTE

Repair of differential pressure gage is limited to replacement of the gage or tubes and fittings.

- (1) Disconnect lower fittings (1), remove tubes (2), and drain into suitable container.
- (2) Unscrew and remove lower elbows (3) from tank (4).
- (3) Inspect and clean tubes (2) for blockage and dirt.
- (4) Replace any damaged parts.
- (5) Coat threads of lower elbows with sealing compound (3) and screw into tank (4).
- (6) Attach tubes (2) to lower elbows (3) at lower fittings (1).

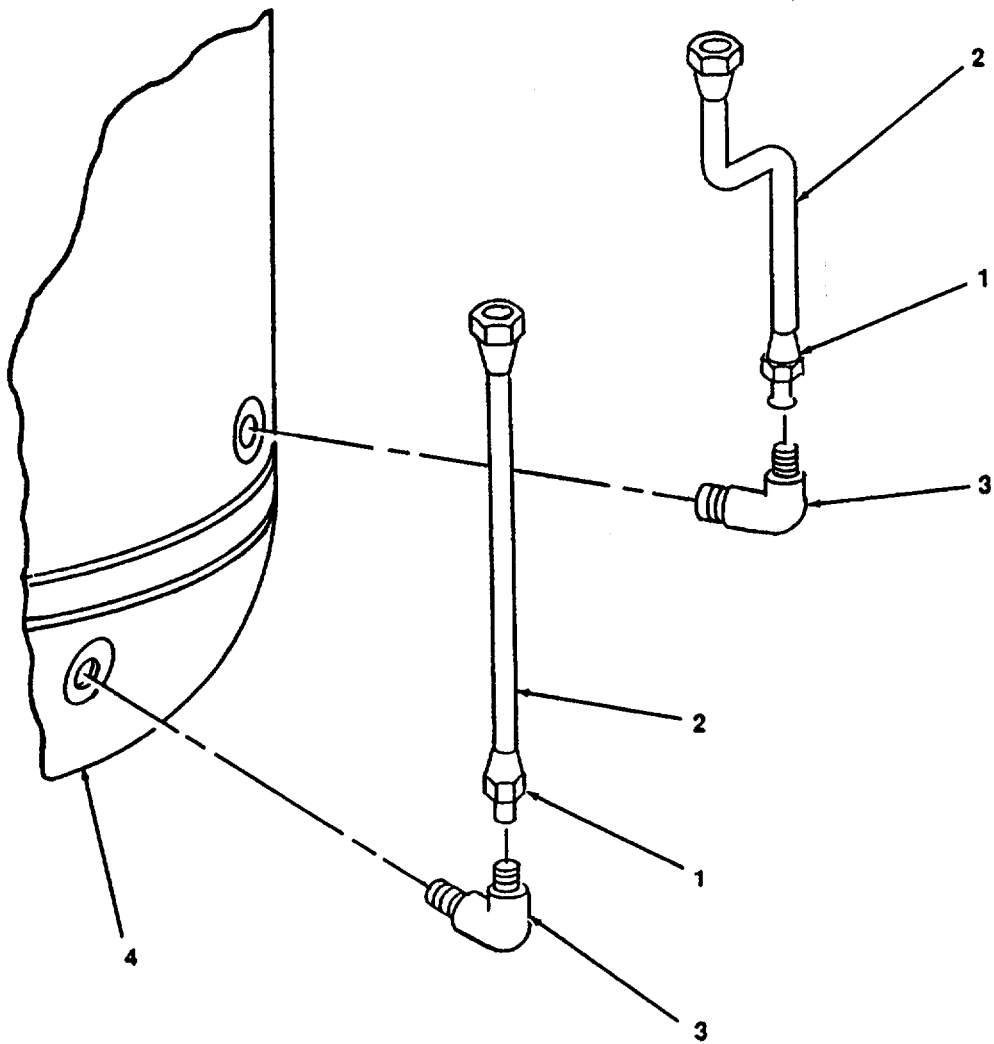

Figure 4-8. Differential Pressure Gage Lines, Repair.

4-16. SIGHT GAGE.

This task covers:

a. Replace

INITIAL SETUP:

Tools:

Material Parts

General Mechanic's Tool Kit (Item 1, Appendix B)

Gasket, Rubber (Appendix F)

a. Replace. (figure 4-9)

- (1) Remove two screws (1), washers (2), sight gage (3) and gasket (4).

NOTE

Check that sight gage ball is in sight gage before installing.

- (2) Install gasket (4), sight gage (3), two washers (2), and screws (1).

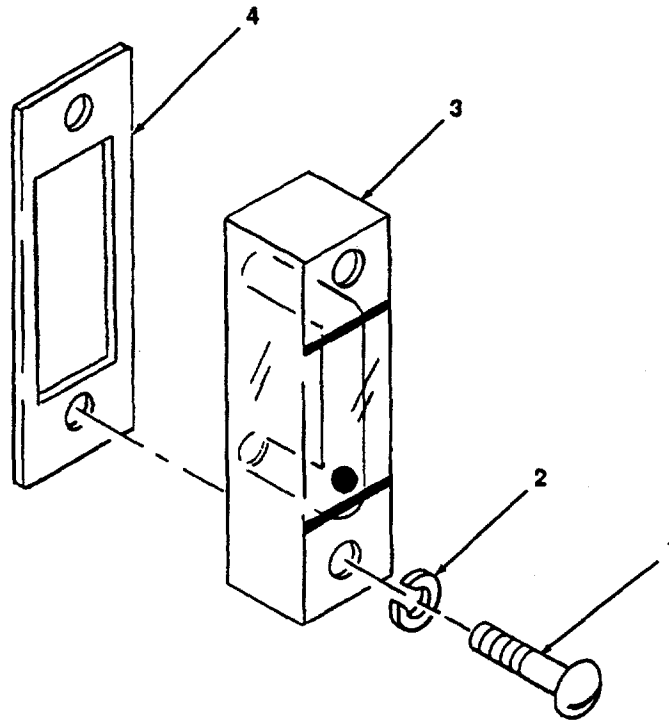

Figure 4-9. Sight Gage, Replace.

4-17. PRESSURE RELIEF VALVE.

This task covers:

a. Replace

INITIAL SETUP:

Tools:

Pipe Wrench (Item 2, Appendix B)

Material Parts

Sealing Compound (Item 1, Appendix E)

Replace. (figure 4-10)

- (1) Remove elbow (1) from pressure relief valve (2).
- (2) Unscrew and remove pressure relief valve (2) from elbow (3).
- (3) Unscrew and remove elbow (3) from tank (4).
- (4) Coat threads of elbow (3) with sealing compound and install on tank (4).
- (5) Coat threads of pressure relief valve (2) and install on elbow (3).
- (6) Coat threads of elbow (1) and install on pressure relief valve (2).

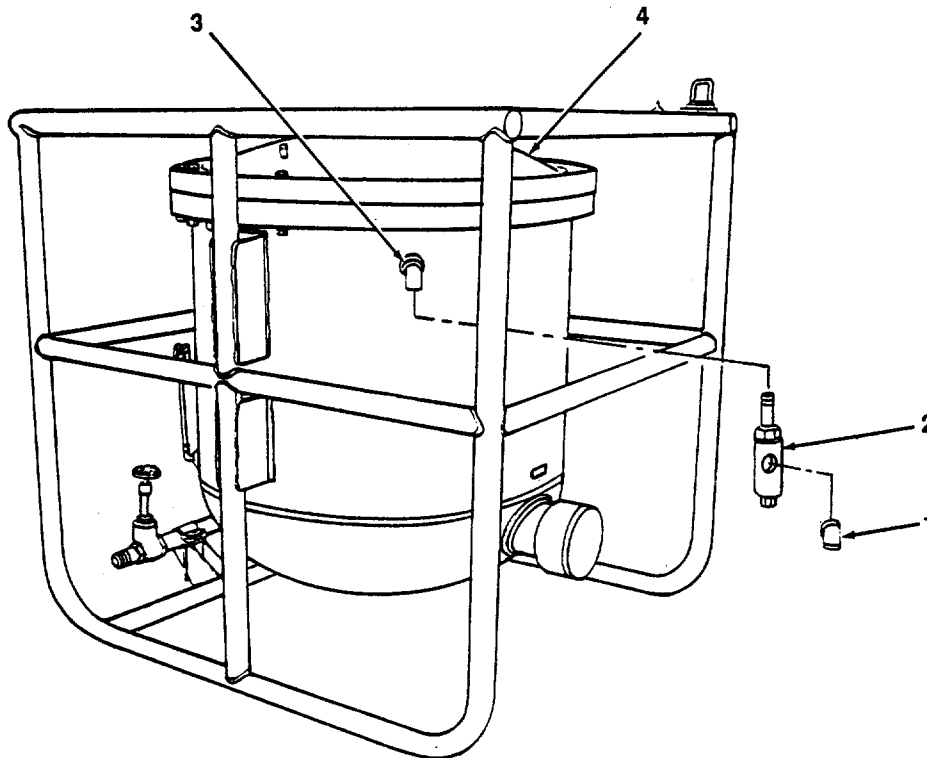

Figure 4-10. Pressure Relief Valve, Replace.

4-18. Manual Drain/Isolation Valve, Lines and Fittings

This task covers:

a. Replace

Repair

Tools:

1 3/8 Inch Wrench (Item 2, Appendix B)
 Pipe Wrench (Item 2, Appendix B)
 General Mechanic's Tool Kit (Item 1, Appendix B)

Equipment Condition

Filter/separator shutdown (para. 2-11).
 Automatic drain valve removed (para. 4-19).

Material/Parts:

Sealing Compound (Item 1, Appendix E)
 Solvent, Drycleaning (Item 4, Appendix E)
 Packing (Appendix F)

a. Replace. (figure 4-11)

(1) Manual drain valve and fittings (removal).

- (a) Remove nut (1) and washer (2).
- (b) Remove hand wheel (3).
- (c) Remove valve body (4).
- (d) Remove elbow (5) and pipe nipple (6).

(2) Isolation valve and fittings (removal and installation).

- (a) Remove nut (7) and washer (8).
- (b) Remove handwheel (9).
- (c) Remove bonnet (10).
- (d) Remove valve body (11).
- (e) Remove pipe nipple (12).
- (f) Remove tee fitting (13).
- (g) Remove pipe nipple (14).
- (h) Remove elbow (1 5) from tank.

NOTE

When installing, coat all pipe and fitting threads with sealing compounds.

- (i) Install elbow (15).
 - (j) Install pipe nipple (14).
 - (k) Install tee fitting (13).
 - (l) Install pipe nipple (12).
 - (m) Install valve body (11).
 - (n) Install bonnet (10).
 - (o) Install handwheel (9).
 - (p) Install washer (8) and nut (7).
- (3) Manual drain valve and fittings (installation).
- (a) Install pipe nipple (6) and elbow (5).
 - (b) Install valve body (4) on pipe (1 6).
 - (c) Install handwheel (3) on bonnet (4) with washer (2) and nut (1).

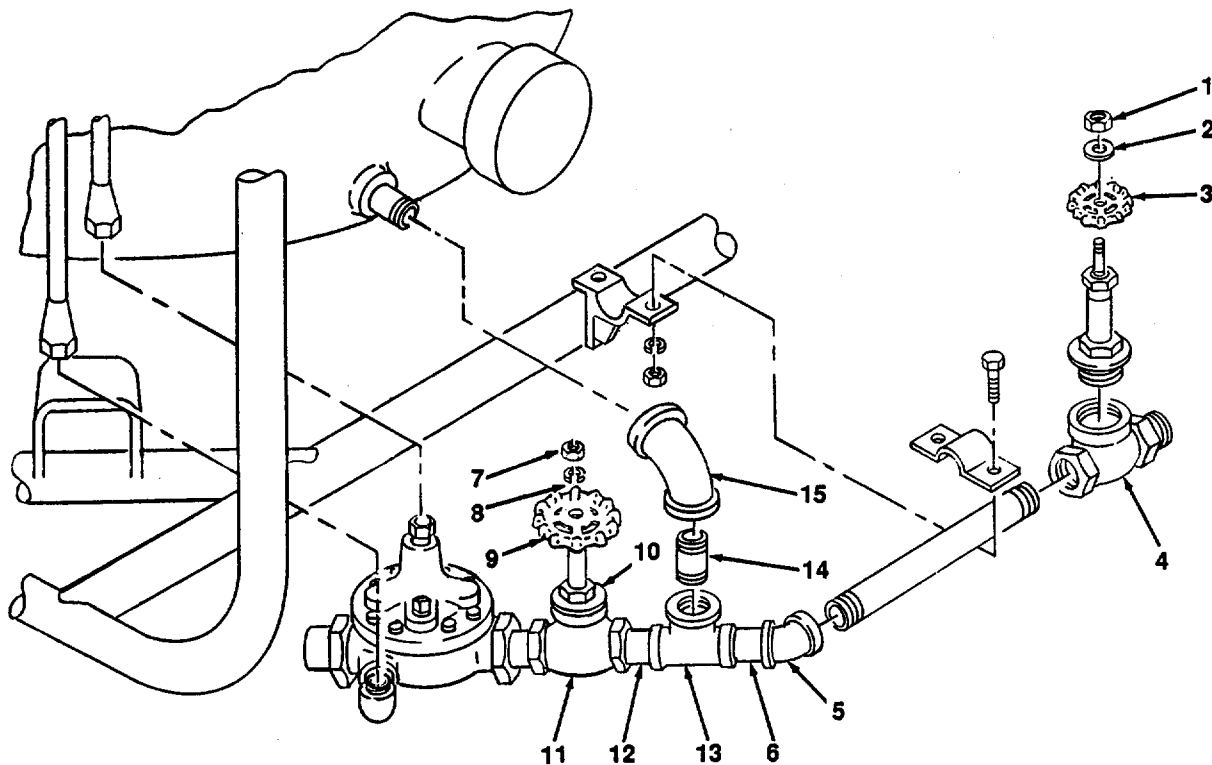

Figure 4-11. Manual Drain Valve, Replace.

4-18. Manual Drain/isolation Valve Lines and Fittings (cont).

- b. Repair. (figure 4-12)

NOTE

Manual drain valve and isolation valve are repaired the same.

- (1) Remove nut (1), washer (2) and hand wheel (3).
- (2) Remove packing nut (4), follower gland (5) and bonnet (6).
- (3) Remove valve stem (8) and disc (9) from bonnet (6), then remove packing (7) and discard.

WARNING

Drycleaning solvent PD-680 used to clean parts is potentially dangerous to personnel and property. Avoid repeated and prolonged skin contact. Do not use near open flame or excessive heat. Flash point of solvent is 100 - 138°F (38 - 600C).

- (4) Clean all items, except packing (7), with dry cleaning solvent.
- (5) Inspect all items and replace packing.
- (6) Install valve stem (8) and disc (9) into bonnet (6).
- (7) Install follower gland (5) and packing nut (4) onto bonnet (6).
- (8) Install bonnet (6) into body (10).
- (9) Install hand wheel (3), washer (2) and nut (1).

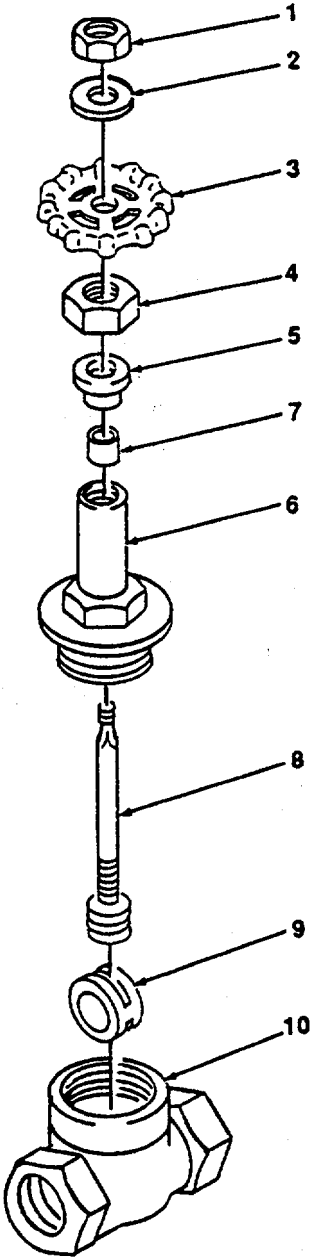

Figure 4-12. Manual Drain Valve, Repair.

FOLLOW-ON MAINTENANCE:
Open fuel inlet.
Start filter/separator pump.

4-19. AUTOMATIC DRAIN VALVE.

This task covers:

a. Removal

b. Repair

c. Installation

INITIAL SETUP:

Tools:

General Mechanic's Tool Kit (Item 1, Appendix B)

Material/Parts:

Sealing Compound (Item 1, Appendix E)

Drycleaning Solvent (Item 4, Appendix E)

Equipment Condition:

Filter/separator shut down (para. 2-11).

a. Removal (figure 4-13)

- (1) Remove bonnet from valve body (1).
- (2) Remove two screws (2), nuts (3), lockwashers (4) and remove clamp support (5).
- (3) Remove pipe (6) and disconnect automatic drain valve lines (7) at fittings (8).
- (4) Turn remaining assembly (9) until it clears the bracket (10).
- (5) Remove automatic drain valve (11) from isolation drain valve.
- (6) Remove pipe nipples (12) from automatic drain valve (11).

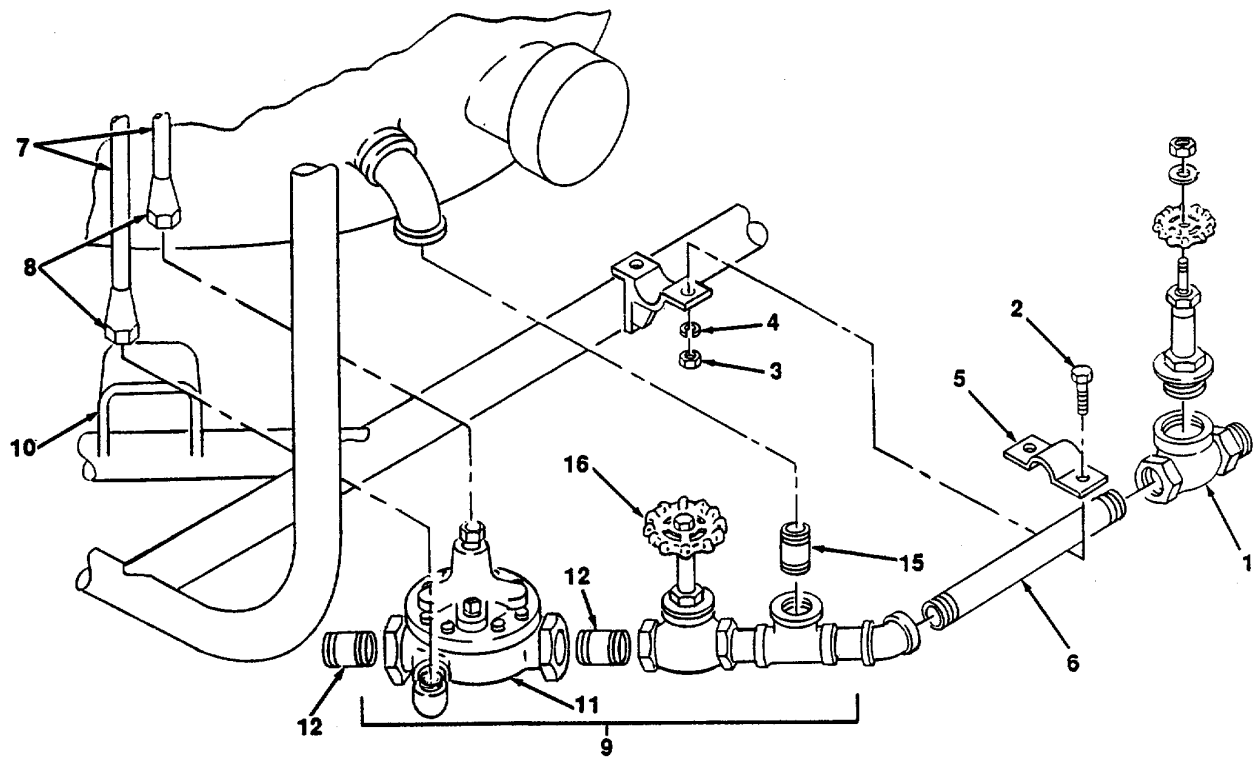

Figure 4-13. Automatic Drain Valve, Replace.

4-19. Automatic Drain Valve (cont).

b. Repair. (figure 4-14)

- (1) Unscrew and remove straight adapter (1) from cover (2).
- (2) Remove eight bolts (3) and cover (2).
- (3) Remove two pipe plugs (4) from cover (2).
- (4) Remove cover and unscrew bearing (5).
- (5) Remove spring (6), stem nut (7), diaphragm washer (8), diaphragm (9), disc retainer (10), and disc (11).
- (6) Remove three spacer washers (12), and one guide disc (13).
- (7) Remove stem (14), seat (15).
- (8) Remove pipe plug (16) from body (17).
- (9) Remove elbow (18) and pipe bushings (19) from body (17).

WARNING

Drycleaning solvent PD-680 used to clean parts is potentially dangerous to personnel and property. Avoid repeated and prolonged skin contact. Do not use near open flame or excessive heat. Flash point of solvent is 100 - 138°F (38 - 60°C).

- (10) Clean all items, except packing, with drycleaning solvent and dry thoroughly.
- (11) Inspect and replace all items that are worn or otherwise damaged.

NOTE

When installing, coat all pipe and fitting threads with sealing compound.

- (12) Install pipe bushings (19) and elbow (18) on body (17).
- (13) Install pipe plugs (16) on body (17).
- (14) Install seat (15) and stem nut (14).
- (15) Install guide disc (13) and three spacer washers (12).

NOTE

To tighten stem nut, it may be necessary to remove diaphragm assembly.

- (16) Install disc (11), disc retainer (10), diaphragm (9) diaphragm washer (8) and stem nut (7).
- (17) Install spring (6) and then install bearing (5) into cover.
- (18) Install two pipe plugs (4) onto cover (2).
- (19) Install cover (2) on body (17) and secure with eight bolts (3).
- (20) Install straight adapter (1) onto cover (2).

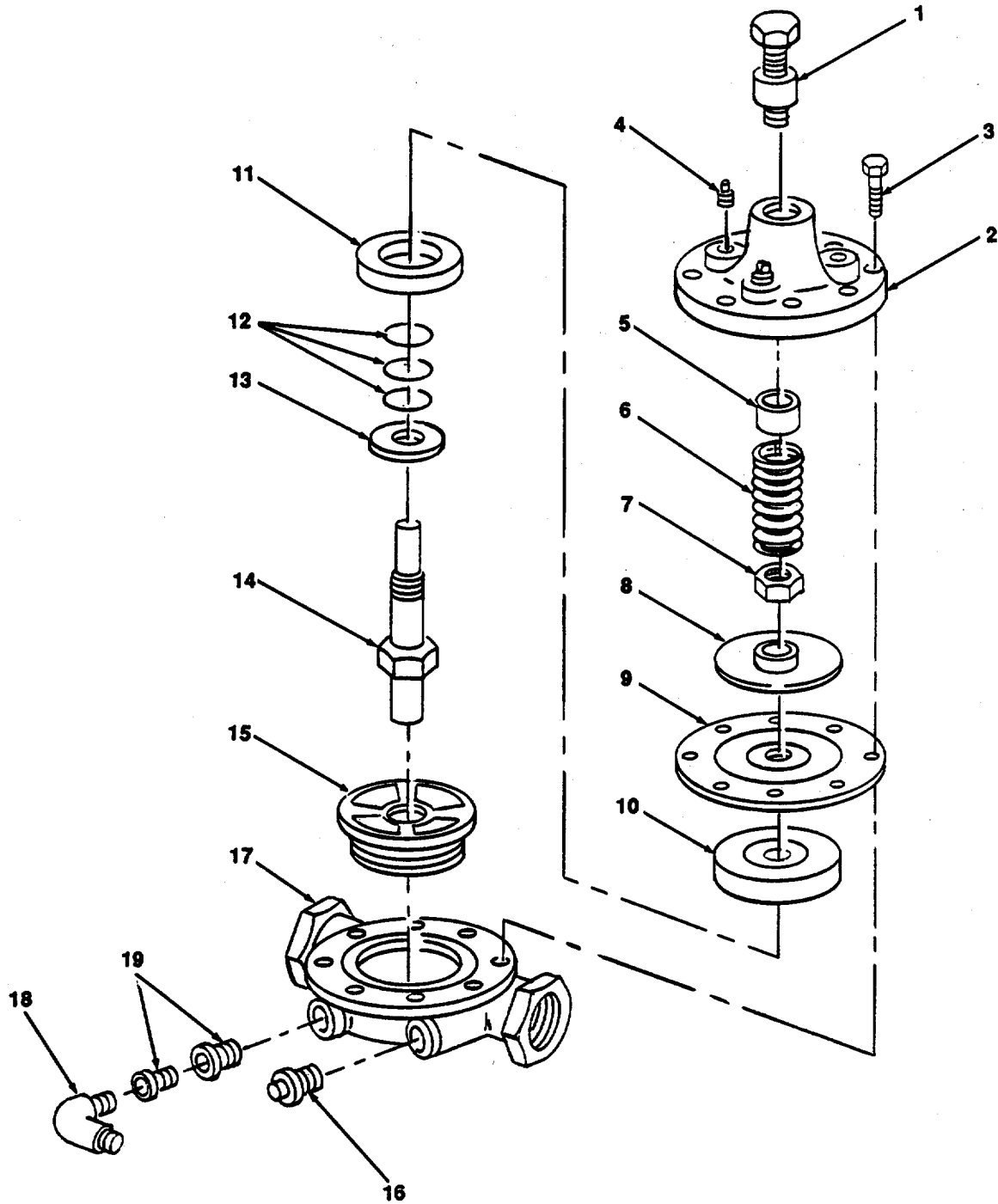

Figure 4-14. Automatic Drain Valve, Repair.

FOLLOW-ON MAINTENANCE:
 Turn-on inlet.
 Start pump.

4-19. **Automatic Drain Valve (cont).**

c. Installation. (figure 4-13)

- (1) Ensure fitting threads are free of dirt and damage.
- (2) Install pipe nipples (12).
- (3) Install automatic drain valve (11) so that bottom of valve stem is visible from discharge side.
- (4) Turn assembly (9) to original position.
- (5) Connect automatic drain valve lines (7) at fittings (8).
- (6) Install pipe (6) with valve body (1) onto elbow of assembly (9).
- (7) Position clamp support (5) on pipe (6) and install two screws (2), lockwashers (4) and nuts (3).
- (8) Ensure valve body is tight and install bonnet.

4-20. FLOAT CONTROL.

This task covers:**a. Removal****b. Repair****c. Installation**

INITIAL SETUP:

Tools:

General Mechanic's Tool Kit (Item 1, Appendix B)

Material Parts

Drycleaning Solvent (Item 4, Appendix E)

Packing (Appendix F)

Gasket (Appendix F)

a. Removal. (figure 4-15)

- (1) Remove three lines (1) from float control (2).
- (2) Remove eight bolts (3), lockwashers (4) and washers (5).
- (3) Remove float control and gasket (2).

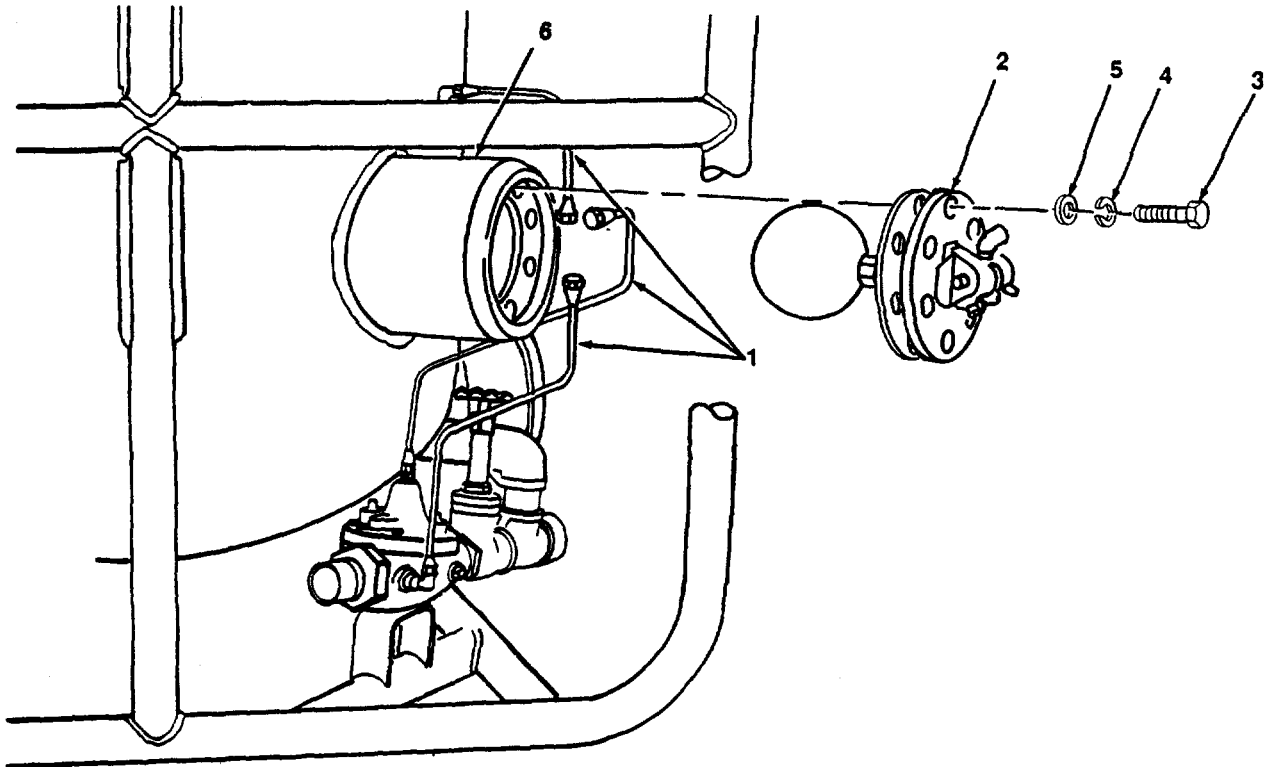
*Figure 4-15. Float Control, Replace.*

4-20. Float Control (cont).**b. Repair. (figure 4-16)**

- (1) Remove float valve (1), pipe nipple (2) and lock pin (3).
- (2) Remove six screws (4), disc guide (5), gasket (6), disc (7), helical spring (8), stem (9), packing (10) and arm float (11).
- (3) Remove two straight adapters (12), two pipe plugs (13), stem locating pin (14) and elbow (15).

WARNING

Drycleaning solvent PD-680 used to clean parts is potentially dangerous to personnel and property. Avoid repeated and prolonged skin contact. Do not use near open flame or excessive heat. Flash point of solvent is 100 - 138°F (38 - 60°C).

- (4) Clean all items, except packings, with drycleaning solvent and dry thoroughly.
- (5) Inspect all items and replace items that are worn or otherwise damaged.
- (6) Install two straight adapters (12), two pipe plugs (13), locating pin (14) and elbow (15).

NOTE

When installing stem, locating pin must be in the up position. (7)
Install new packing (10), arm float (11), stem (9), lock pin (3), helical spring (8), disc (7), gasket (6), disc guide (5), and six screws (4).

- (8) Install pipe nipple (2) and float valve (1).

c. Installation. (figure 4-15)

- (1) Replace gasket and install float control (2) in housing (6).
- (2) Install eight washers (5), lockwashers (4) and bolts (3).
- (3) Install three lines (1) to float control (2).

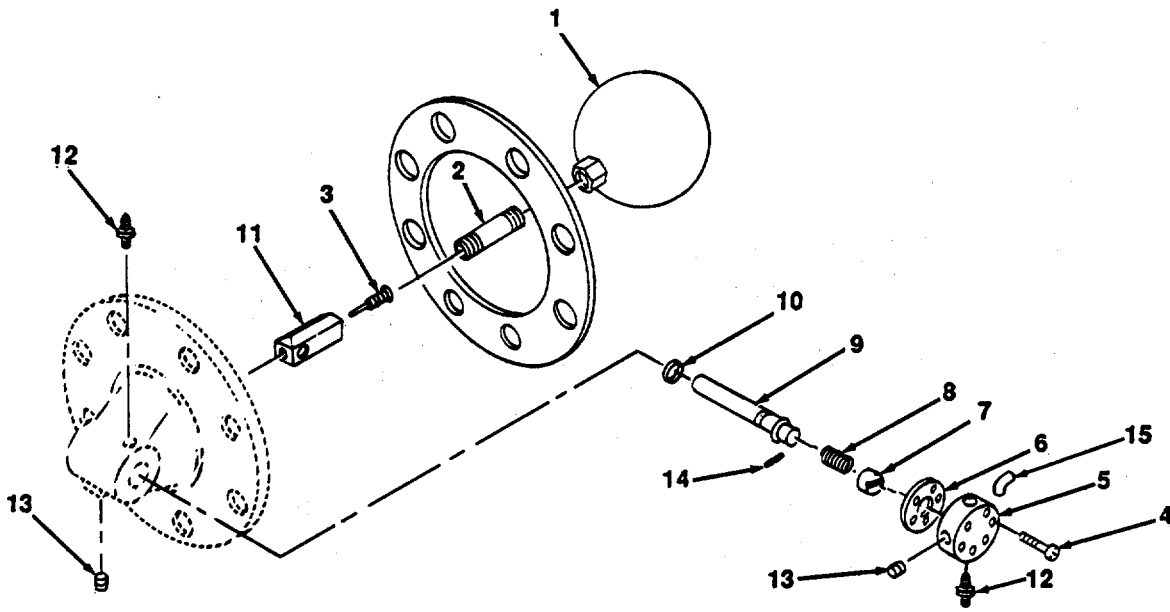

Figure 4-16. Float Control, Repair.

4-21. Grounding Assembly (cont).

This task covers:

a. Replace

b. Repair

INITIAL SETUP:

Tools:

General Mechanic's Tool Kit (Item 1, Appendix B)

Material Parts

Drycleaning Solvent (Item 4, Appendix E)

a. Replace. (figure 4-1 7)

- (1) Loosen screw (1) on electrical clamp (2).
- (2) Remove wire (3) from electrical clamp (2).
- (3) Remove grounding rods (4).
- (4) Remove two screws (5) and electrical clamp (2).
- (5) Install electrical clamps (2) on frame (6) with two screws (5).
- (6) Insert wire (3) into electrical clamp (2).
- (7) Tighten screw (1).

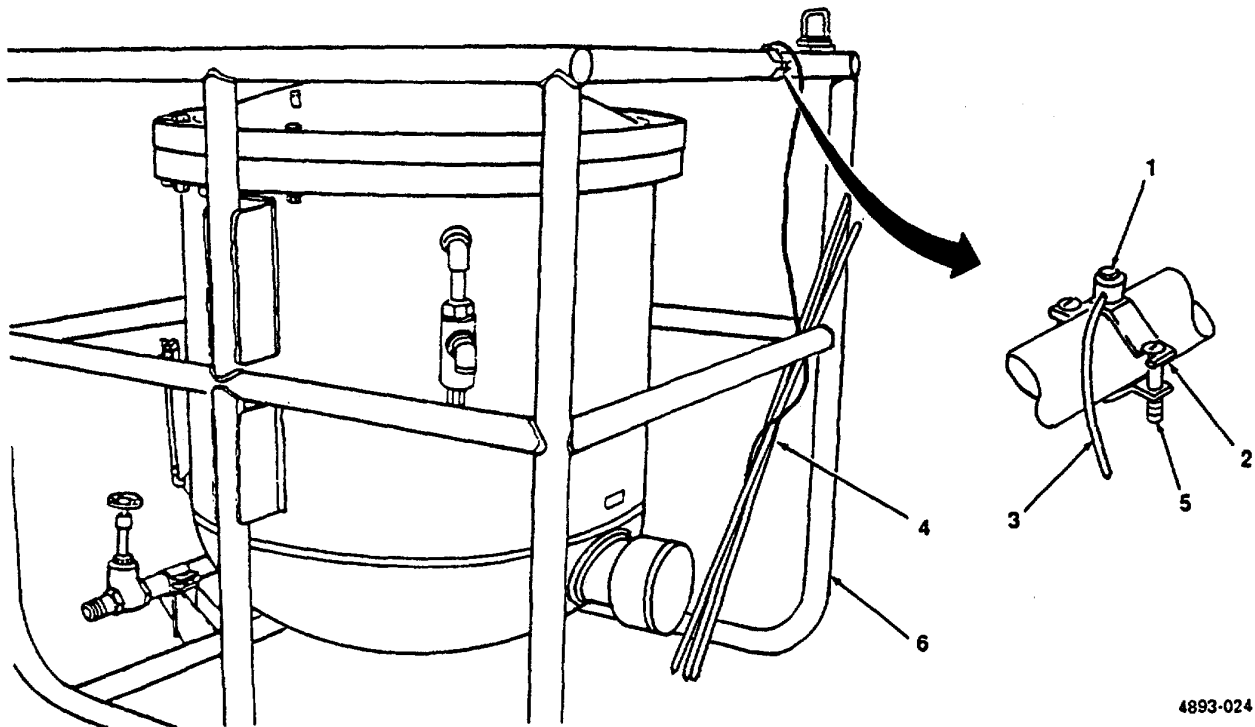

4893-024

Figure 4-17. Grounding Assembly, Replace.

4-21. Grounding Assembly (cont).**b. Repair. (figure 4-18)**

- (1) Remove screw (1) and clamp (2).
- (2) Remove wire (3) from grounding rods (4).

WARNING

Drycleaning solvent PD-680 used to clean parts is potentially dangerous to personnel and property. Avoid repeated and prolonged skin contact. Do not use near open flame or excessive heat. Flash point of solvent is 100 - 138°F (38 - 600C).

- (3) Clean grounding rod (4) with drycleaning solvent. Repair or replace wire, clamps and rods as necessary.
- (4) Install wire (3) on grounding rods (4).
- (5) Secure with clamp (2) and screw (1).

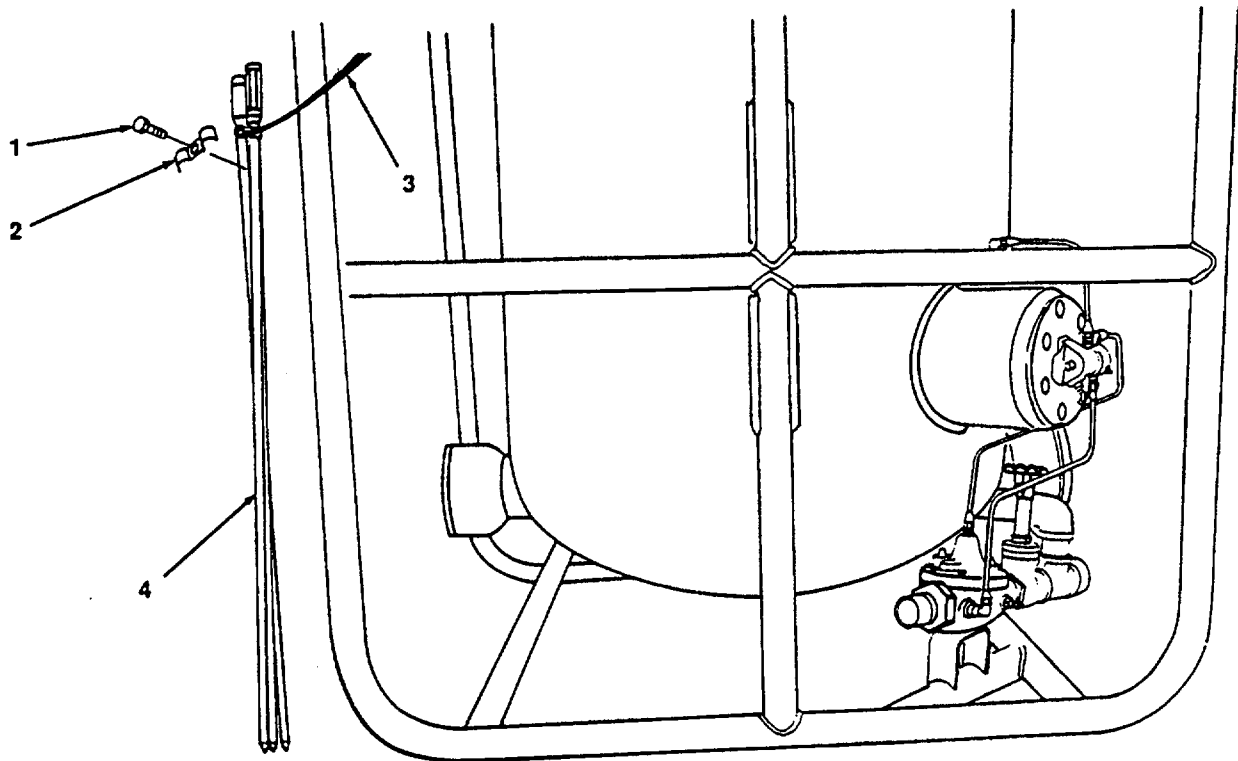

Figure 4- 18. Grounding Assembly, Repair.

SECTION VI. PREPARATION FOR SHIPMENT OR STORAGE

Paragraph		Page
4-22	Short Term Storage	4-32
4-23	Intermediate Storage	4-32
4-24	Administrative Storage of Equipment	4-32
4-25	Preparation for Shipment	4-33

4-22. **Short Term Storage.** Store the filter/separator as follows:

- a. Isolate the filter/separator from the pipeline by closing the inlet valve.
- b. Open the manual drain valves and drain the fuel in the tank into a suitable container.
- c. Open the drain plug at the bottom of the tank and drain fuel out of filter/separator. Disconnect ground rod.
- d. Disconnect inlet and outlet hoses from filter/separator.

WARNING

Use a lifting device, with a one ton lifting capacity, to remove unit from pipeline. Do not allow unit to swing back and forth while suspended. Death or serious injury to personnel or damage to the equipment may result if this warning is ignored.

- e. Remove unit from pipeline.

4-23. **Intermediate Term Storage.** Refer to the following documents for information relative to storing the filter/separator.

- a. TM 38-230-1 Preservation and packing of military equipment.
- b. AR-750-1 Army Materiel Maintenance Policy and Retail Maintenance Operations.
- c. MIL-F-52429 Packaging of fuel separators.

4-24. **Administrative Storage of Equipment .**

a. Placement of equipment in administrative storage should be for short periods of time when a shortage of maintenance effort exists. Items should be in mission readiness within 24 hours or within the time factors as determined by the directing authority. During the storage period appropriate maintenance records will be kept.

b. Before placing equipment in administrative storage, current maintenance services and equipment serviceable criteria (ESC) evaluations should be completed, shortcomings and deficiencies should be corrected, and all modification work orders (MWO's) should be applied.

c. Storage site selection. Inside storage is preferred for items selected for administrative storage. If inside storage is not available, trucks, vans, conex containers and other containers may be used.

4-25. **Preparation for Shipment.** Refer to the following documents.

- a. TM 38-230-1 Preservation and Packing of Military Equipment.
- b. MIL-F-52429 Packing of Fuel Separators.

CHAPTER 5

DIRECT SUPPORT MAINTENANCE

5-1. FRAME ASSEMBLY.

This task covers:

a. Repair

INITIAL SETUP:

Reference

TM 43-0139 Painting Instructions
for Field Use.
TM 9-237 Welding Theory and Application

Tools

General Mechanics Tool Kit (Item 1,
Appendix B), Welding Shop (Item 3,
Appendix B)

Repair

- (1) Inspect frame assembly for corrosion.
- (2) If frame is corroded, clean and touch up paint. Refer to TM 43-40139 for painting instructions.
- (3) Inspect all weld joints for cracks or damage. Weld as necessary in accordance with TM 9-237.
- (4) If frame is bent, straighten as necessary.

APPENDIX A

REFERENCES

A-1. **Scope.** This appendix contains all forms, pamphlets and technical manuals referenced in this manual.

A-2. **Forms.**

Recommended Changes to Publications..... DA Form 2028
Recommended Changes to Publications..... DA Form 2028-2
Equipment Inspection and Maintenance Worksheet..... DA Form 2404
Quality Deficiency Report (QDR)..... SF 368
Report of Discrepancy (ROD) SF 364

A-3. **Pamphlets.**

The Army Maintenance Management System (TAMMS)..... DA Pam 738-750
Consolidated Index of Army Publication and Blank Forms DA Pam 25-30

A-4. **Technical Manuals.**

Painting Instructions or Field Use..... TM 43-0139
Procedures for Destruction of Equipment to Prevent Enemy Use..... TM 750-244-3
Preservation and Packing of Military Equipment TM 38-230-1
Welding Theory and Application TM 9-237

A-5. **Technical Bulletins.**

Hand Portable Fire Extinguishers Approved for Army Use TB 5-4200-200-10

A-6. **Field Maintenance.**

First Aid for Soldiers FM 21-11

A-7. **Army Regulations.**

Army Materiel Maintenance Policy and Retail Maintenance Operations AR-750-1

A-1/(A-2 blank)

APPENDIX B

MAINTENANCE ALLOCATION CHART

SECTION I. INTRODUCTION

B-1. General.

a. This section provides a general explanation of all maintenance and repair functions authorized at various maintenance levels.

b. The Maintenance Allocation Chart (MAC) in Section II designates overall authority and responsibility for the performance of maintenance functions on the filter/separator. The application of the maintenance functions to the filter/separator will be consistent with the capacities and capabilities of the designated maintenance levels.

c. Section III lists the tools and test equipment (both special tools and common tool sets) required for each maintenance function as referenced from Section II.

d. Section IV contains supplemental instructions and explanatory notes for a particular maintenance function.

B-2. **Maintenance Functions.** Maintenance functions will be limited to and defined as follows:

a. Inspect. To determine the serviceability of an item by comparing its physical, mechanical, and/or electrical characteristics with established standards through examination (e.g. by sight, sound, or feel).

b. Test. To verify serviceability by measuring the mechanical, pneumatic, hydraulic, or electrical characteristics of an item and comparing those characteristics with prescribed standards.

c. Service. Operations required periodically to keep an item in proper operating condition, i.e., clean (includes decontaminate, when required), to preserve, to drain, to paint, or to replenish fuel, lubricants, chemical fluids or gases.

d. Adjust. To maintain or regulate, within prescribed limits, by bringing into proper or exact position, or by setting the operating characteristics to specified parameters.

e. Aline. To adjust specified variable elements of an item to bring about optimum or desired performance.

f. Calibrate. To determine and cause corrections to be made or to be adjusted on instruments or test, measuring, and diagnostic equipment used in precision measurement. Consists of comparisons of two instruments, one of which is a certified standard of known accuracy, to detect and adjust any discrepancy in the accuracy of the instrument being compared.

g. Remove/Install. To remove and install the same item when required to perform service or other maintenance functions. Install may be the act of emplacing, seating or fixing into position a spare, repair part, or module (component or assembly) in a manner to allow the proper functioning of equipment or system.

h. Replace. To remove an unserviceable item and install a serviceable counterpart in its place. "Replace" is authorized by the MAC and is shown as the 3rd position code of the SMR code.

i. Repair. The application of maintenance services, including fault location/troubleshooting, removal/installation, and disassembly/assembly procedures, and maintenance actions to identify trouble and restore serviceability to an item by correcting specific damage, fault, malfunction, or failure in a part, subassembly, module (component or assembly), end item, or system.

j. Overhaul. That maintenance effort (service/action) prescribed to restore an item to a completely serviceable/operational condition as required by maintenance standards in appropriate technical publications (i.e., DMWR). Overhaul is normally the highest degree of maintenance performed by the Army. Overhaul does not normally return an item to like new condition.

k. Rebuild. Consists of those services/actions necessary for the restoration of unserviceable equipment to like new condition in accordance with original manufacturing standards. Rebuild is the highest degree of materiel maintenance applied to Army equipment. The rebuild operation include the act of returning to zero those age measurements (hours/miles, etc.) considered in classifying Army equipment/components.

B-3. Explanation of Columns in the MAC, Section II.

a. Column 1. Group Number. Column 1 lists functional group code numbers the purpose of which is to identify maintenance significant components, assemblies, subassemblies, and modules with the next higher assembly. End item group shall be "00".

b. Column 2. Component/Assembler. Column 2 contains the names of components, assemblies, subassemblies, and modules for which maintenance is authorized.

c. Column 3. Maintenance/Function. Column 3 lists the functions to be performed on the item listed in Column 2. (For detailed explanation of these functions, see paragraph B-2).

d. Column 4. Maintenance Level. Column 4 specifies, by the listing to work time figure in the appropriate subcolumn(s), the level of maintenance authorized to perform the function listed in Column 3. This figure represents the active time required to perform the function listed in indicated level of maintenance. If the number or complexity of the tasks within the listed maintenance functions vary at different maintenance levels, appropriate work time figures will be shown, for each level. The work time figure represents the average time required to restore an item (assembly, subassembly, component, module end item, or system) to a serviceable condition under typical field operating conditions. This time includes preparation time (including any necessary disassembly/assembly time), troubleshooting/fault location time, and quality assurance/quality control time in addition to the time required to perform the specific tasks identified for the maintenance functions authorized in the maintenance allocation chart. The symbol designations for the various maintenance levels are as follows:

- C - Operator or crew
- O - Unit Maintenance
- F - Direct Support Maintenance
- H - General Support Maintenance
- D - Depot Maintenance

e. Column 5. Tools and Equipment. Column 5 specifies by code, those common tool sets (not individual tools) and special tools, TMDE, and support equipment required to perform the designated function.

f. Column 5. Remarks. This column shall, when applicable contain a letter code, in alphabetic order, which shall be keyed to the remarks contained in Section IV.

B-4. Explanation of Columns In Tool and Test Equipment Requirements, Section III.

- a. Column 1. Reference Code. The tool and test equipment reference code correlates with a code used in the MAC, Section II, Column 5.
- b. Column 2. Maintenance Category. The lowest category of maintenance authorized to use the tool or test equipment.
- c. Column 3. Nomenclature. Name or identification of the tool or test equipment.
- d. Column 4. National Stock Number. The National stock number of the tool or test equipment.
- e. Column 5. Tool Number. The manufacturer's part number.

B-5. Explanation of Columns In Remarks, in Section IV.

- a. Column 1. Reference Code. The code recorded in column 6, Section II.
- b. Column 2. Remarks. This column lists information pertinent to the maintenance function being performed as indicated in the MAC, Section II.

SECTION II. MAINTENANCE ALLOCATION CHART

(1) GROUP NO.	(2) COMPONENT/ ASSEMBLY	(3) MAINT. FUNCTION	(4) MAINTENANCE LEVEL					(5) TOOLS & EQUIP.	(6) REMARKS
			UNIT		DS	GS	DEPOT		
			C	O	F	H	D		
00	Filter/Separator								
01	Cover Assembly	Inspect Repair Replace	0.5	0.1 0.5 0.5				1 1	
02	Canister	Inspect Service Replace		0.5 1.0 1.0					
	Clamp Band	Inspect Replace		0.5 0.5					
	Filter Element	Inspect Replace		1.0 1.0					

SECTION II MAINTENANCE ALLOCATION CHART

(1) GROUP NO.	(2) COMPONENT/ ASSEMBLY	(3) MAINT. FUNCTION	(4) MAINTENANCE LEVEL					(5) TOOLS & EQUIP.	(6) REMARKS
			UNIT		DS	GS	DEPOT		
			C	O	F	H	D		
03	Gages, Mounting Lines and Fittings	Inspect		0.5					
		Repair		0.5				1	
		Replace		0.5				1	
	Differential Pressure Gage	Inspect		0.1					
		Repair		0.5				1	
		Replace		0.5				1	
Sight Gage	Inspect		0.1						
	Replace		0.3				1		
04	Valves and Lines	Inspect	0.5						
		Service		1.0					
		Repair		1.0					
		Replace		1.0					
	Pressure Relief Valve	Inspect	0.1						2
		Replace		0.5					2
	Manual Drain/Isolation Valve	Inspect	0.1	0.1					
		Repair		1.5					1, 2
		Replace		1.0					1, 2
	Automatic Drain Valve	Inspect	0.1	0.5					
		Repair		1.8					1,2
		Replace		0.0					1,2
Float Control Valve	Inspect	0.1	0.5						
	Repair		1.0					1	
	Replace		0.5					1	
05	Grounding Assy	Inspect	0.5						
		Repair		0.5					1
		Replace		0.1					1
06	Frame Assembly	Inspect							
		Repair			6.0				

SECTION III. TOOL AND TEST EQUIPMENT REQUIREMENTS

Tool or test equipment ref code (1)	Maintenance category (2)	Nomenclature (3)	National NATO stock number (4)	PN Tool Number (5)
1	0	General Mechanics Tool Kit	5180-00-699-5273	
2	0	Shop Equipment Automotive Maintenance and Repair No. 1 Common	4910-00-754-0654	
3	F	Welding Shop, Trailer Mounted	3431-01-090-1231	

SECTION IV. Remarks

Not Applicable

B-5/(B-6 blank)

APPENDIX C

COMPONENTS OF END ITEM AND BASIC ISSUE ITEMS LISTS

SECTION I. INTRODUCTION

C-1. **Scope.**

This appendix lists components of end item and basic issue items for the filter/separator to help you inventory items required for safe and efficient operation.

C-2. **General.**

The Components of End Item and Basic Issue Items Lists are divided into the following sections:

a. Section II. Components of End Item. This listing is for informational purposes only, and is not authority to requisition replacements. These items are part of the end item, but are removed and separately packaged for transportation or shipment. As part of the end item, these items must be with the end item whenever it is issued or transferred between property accounts. Illustrations are furnished to assist you in identifying the items.

b. Section III. Basic Issue Items. These are the minimum essential items required to place the filter/separator in operation, to operate it, and to perform emergency repairs. Although shipped separately packaged, BII must be with the shelter during operation and whenever it is transferred between property accounts. The illustrations will assist you with hard-to-identify items. This manual is your authority to request/requisition replacement BII, based on TOE/MTOE authorization of the end item.

C-3. **Explanation of Columns.**

The following provides an explanation of columns found in the tabular listings:

a. Column (1) - Illustration Number (Illus Number). This column indicates the number of the illustration in which the item is shown.

b. Column (2) - National Stock Number. Indicates the National stock number assigned to the item and will be used for requisitioning purposes.

c. Column (3) - Description. Indicates the Federal item name and, if required, a minimum description to identify and locate the item. The last line for each item indicates the CAGE (in parentheses) followed by the part number.

d. Column (4) - Unit of Measure (U/M). indicates the measure used in performing the actual operation/maintenance function. This measure is expressed by a two-character alphabetical abbreviation (e.g., ea, in, pr).

e. Column (5) - Quantity required (QTY RQR). Indicates the quantity of the item authorized to be used with/on the equipment.

SECTION II. COMPONENTS OF END ITEM

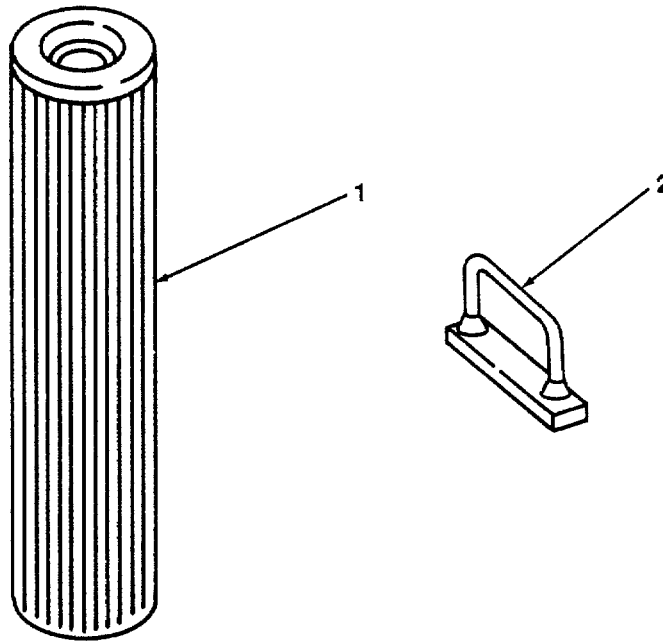

(1) Illus Number	(2) National Stock Number	(3) Description FSCM and Part Number	Usable On Code	(4) U/M	(5) Qty Rqr
1	4330-00-983-0998	Filter Element, MIL-F-52308 (81349)		ea	30
2	5120-01-239-2256	Wrench, Spanner, 13217E5367 (97403)		ea	1

SECTION III. BASIC ISSUE ITEMS

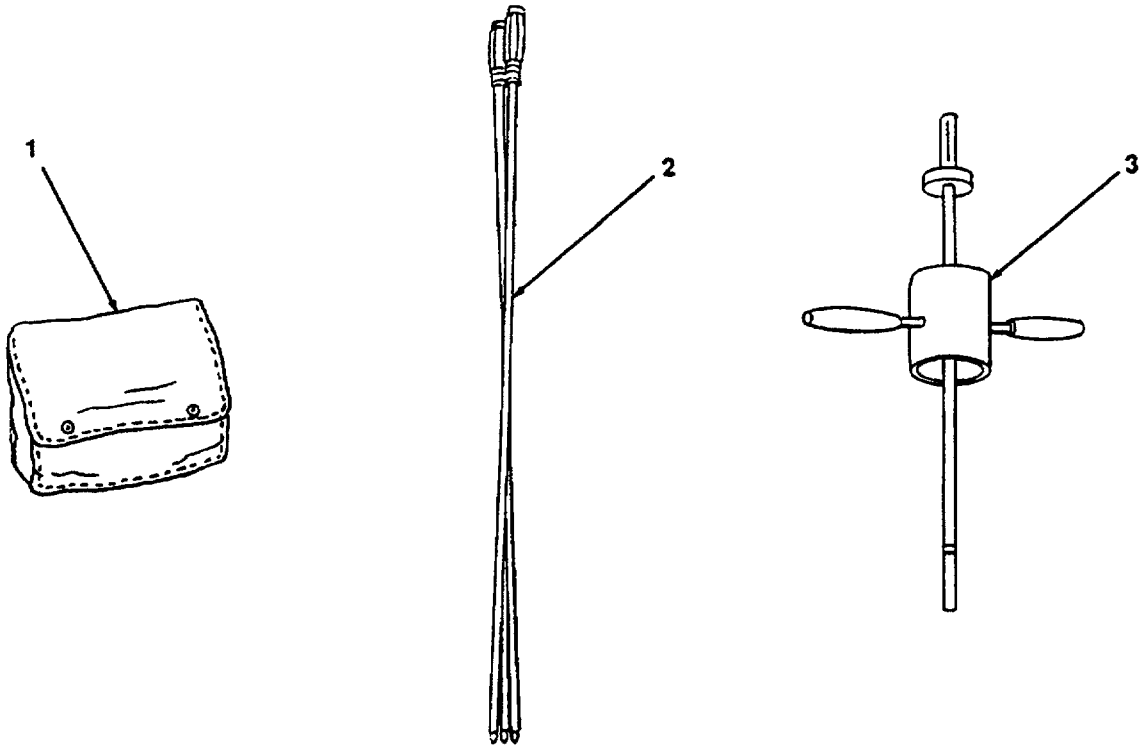

(1) Illus Number	(2) National Stock Number	(3) Description CAGEC and Part Number	Usable On Code	(4) U/M	(5) Qty Rqr
1	5220-00-559-9618	Case, Department of Army Technical Manual; Operator's, Unit and Direct Support Maintenance Manual (Including Repair Parts and Special Tools List) TM 10-4330-234-13&P		ea	1
2	5975-00-878-3791	Ground Rod Assembly, MIL-R-1161 (81349)		ea	1
3	5120-00-013-1676	Ground Rod Puller		ea	1

C-3/(C-4 blank)

APPENDIX D

ADDITIONAL AUTHORIZATION LIST

Not Applicable

D-1/(D-2 blank)

APPENDIX E

EXPENDABLE/DURABLE SUPPLIES AND MATERIALS LIST

SECTION I. INTRODUCTION

E-1. **Scope.** This listing is for informational purposes only and is not authority to requisition the listed items. These items are authorized to you by CTA 50-970, Expendable/Durable Items (except medical, class V, repair parts, and heraldic items).

E-2. **Explanation of Columns.**

a. Column (1) - Item Number. This number is assigned to the entry in the listing and is referenced in the narrative instructions to identify the material (e.g., "Use cleaning compound, item 5, appendix C").

b. Column (2) - Level. This column identifies the lowest level of maintenance that requires the listed item.

- C - Operator/Crew
- O - Unit Maintenance
- F - Direct Support Maintenance
- H - General Support Maintenance

c. Column (3) - National Stock Number. This is the National stock number assigned to the item; use it to request or requisition the item.

d. Column (4) - Description. Indicates the Federal item name, and, if required, a description to identify the item. The last line for each item indicates the Commercial and Government Entity Code (CAGEC) followed by the part number.

e. Column (5) - Unit of Measure (U/M). Indicates the measure used in performing the actual maintenance function. This measure is expressed by a two-character alphabetical abbreviation (e.g., EA, IN., PR). If the unit of measure differs from the unit of issue, requisition the lowest unit of issue that will satisfy your requirements.

SECTION II. EXPENDABLE/DURABLE SUPPLIES AND MATERIALS LIST

(1) Item number	(2) Level	(3) National stock number	(4) Description	(5) U/M
1	O		Sealing Compound, MIL-S-7916 (81349)	QT
2	O	6850-00-880-7616	Silicone Compound, MIL-S-8660 (81349)	QT
3	O		Cloth, Wiping	BL
4	O	6850-00-281-1985	Drycleaning Solvent, Fed. Spec. PD-680	GL
5	O		Goggles, Safety	EA
6	O		Gloves, Rubber	PR

E-1/(E-2 blank)

APPENDIX F

OPERATOR'S, UNIT AND DIRECT
SUPPORT MAINTENANCE
REPAIR PARTS AND SPECIAL TOOLS LIST

SECTION I. INTRODUCTION

1. SCOPE. This RPSTL lists and authorizes spares and repair parts; special tools; special test, measurement, and diagnostic equipment (TMDE); and other special support equipment required for performance of unit, direct support and general support maintenance of the Air Conditioner. It authorizes the requisitioning, issue, and disposition of spares, repair parts and special tools as indicated by the source, maintenance and recoverability (SMR) codes.

2. GENERAL. In addition to this section, Introduction, this Repair Parts and Special Tools List is divided into the following sections:

a. Section II. Repair Parts List. A list of spares and repair parts authorized by this RPSTL for use in the performance of maintenance. This list also includes parts which must be removed for replacement of the authorized parts. Parts lists are composed of functional groups in ascending alphanumeric sequence, with the parts in each group listed in ascending figure and item number sequence. Bulk materials are listed in item name sequence. Repair parts kits are listed separately in functional groups in Section II. Repair parts for repairable special tools are also listed in this section. Items listed are shown in the associated illustration(s)/figure(s).

b. Section III. Special Tools List. A list of special tools, special TMDE, and other special support equipment authorized by this RPSTL (as indicated by Basis of Issue (BOI) information in DESCRIPTION AND USABLE ON CODE column) for the performance of maintenance.

c. Section IV. Cross-Reference Index. A list, in National Item Identification Number (NIIN) sequence, of all national stock numbered items appearing in the listing, followed by a list in alphanumeric sequence of all part numbers appearing in the listings. National stock numbers and part numbers are cross referenced to each illustration figure and item number appearance. The figure and item number index lists figure and item numbers in alphanumeric sequence and cross references NSN, CAGEC and part number.

3. EXPLANATION OF COLUMNS (Sections II AND III).

a. ITEM NO. (Column (1)). Indicates the number used to identify items called out in the illustration.

b. SMR Code (Column (2)). The Source, Maintenance, and Recoverability (SMR) code is a 5-position code containing supply/requisitioning information, maintenance category authorization criteria, and disposition instruction, as shown in the following breakout:

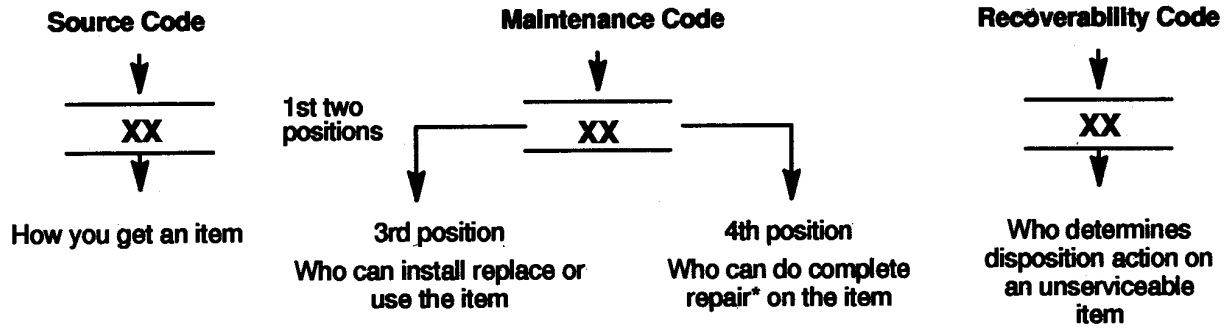

* Complete Repair: Maintenance capacity, capability, and authority to perform all corrective maintenance tasks of the "Repair" function in a use/user environment in order to restore serviceability to a failed item.

(1) **Source Code.** The source code tells you how you get an item needed for maintenance, repair, or overhaul of an end item/equipment. Explanations of source codes follow.

Code	Explanation
PA	Stocked items; use the applicable NSN to request/requisition items with these source codes. They are authorized to the category indicated by the code entered in the 3rd position of the SMR code. **NOTE : Items coded PC are subject to deterioration.
PB	
PC**	
PD	
PE	
PF	
PG	
KD	Items with these codes are not to be requested/requisitioned individually. They are part of a kit which is authorized to the maintenance category indicated in the 3rd position of the SMR code. The complete kit must be requisitioned and applied.
KF	
KB	
MO - (Made at org AVUM level)	Items with these codes are not to be requested/requisitioned individually. They must be made from bulk material which is identified by the part number in the DESCRIPTION and USABLE ON CODE (UOC) column and listed in the Bulk Material group of the repair parts list in the RPSTL. If the item is authorized to you by the 3rd position code of the SMR code, but the source code indicates it is made at a higher level, order the item from the higher level of maintenance.
MF - (Made at DS/AVUM level)	
MH - (Made at GS level)	
ML - (Made at Specialized Repair Activity (SRA))	
MD - (Made at Depot)	

Code	Explanation
AO - (org Assembled by AVUM Level)	Items with these codes are not to be requested/requisitioned individually. The parts that make up the assembled item must be requisitioned or fabricated and assembled at the level of maintenance indicated by the source code. If the 3rd position code of the SMR code, authorizes you to replace the item, but the source code indicates the items are assembled at a higher level, order the item from the higher level of maintenance.
AF - (Assembled by DS/AVUM Level)	
AH - (Assembled by GS Category)	
AL - (Assembled by SRA)	
AD - (Assembled by Depot)	

Code	Explanation
XA -	Do not requisition an "XA"-coded item. Order its next higher assembly. (Also, refer to the NOTE below.)
XB -	If an "XB" item is not available from salvage, order it using the CAGE Code and part number given.
XC -	Installation drawing, diagram, instruction sheet, field service drawing, that is identified by manufacturer's part number.
XD -	Item is not stocked. Order an "XD"-coded item through normal supply channels using the CAGE Code and part number given, if no NSN is available.

NOTE

Cannibalization or controlled exchange, when authorized, may be used as a source of supply for items with the above source codes, except for those source coded "XA" or those aircraft support items restricted by requirements of AR 750-1

(2) Maintenance Code. Maintenance codes tell you the level(s) of maintenance authorized to USE and REPAIR support items. The maintenance codes are entered in the third and fourth positions of the SMR code as follows:

(a) The maintenance code entered in the third position tells you the lowest maintenance level authorized to remove, replace, and use an item. The maintenance code entered in the third position will indicate authorization to the following levels of maintenance.

Code	Application/Explanation
C -	Crew or operator maintenance done within unit/AVUM maintenance.
O -	Unit level VAVUM maintenance can remove, replace, and use the item.
F -	Direct support/AVIM maintenance can remove, replace, and use the item.
H -	General support maintenance can remove, replace, and use the item.

L - Specialized repair activity can remove, replace, and use the item.

D - Depot can remove, replace, and use the item.

(b) The maintenance code entered in the fourth position tells whether or not the item is to be repaired and identifies the lowest maintenance level with the capability to do complete repair (i.e., perform all authorized repair functions). This position will contain one of the following maintenance codes. NOTE: Some limited repair may be done on an item at a lower level of maintenance, if authorized by the Maintenance Allocation Chart (MAC) and SMR codes.

Code	Application/Explanation
O	Unit VAVUM is the lowest level that can do complete repair of the item.
F	Direct support VAVIM is the lowest level that can do complete repair of the item.
H	General Support is the lowest level that can do complete repair of the item.
L	Specialized repair activity is the lowest level that can do complete repair of the item.
D	Depot is the lowest level that can do complete repair of the item.
Z	Nonreparable. No repair is authorized.
B	No repair is authorized. No parts or special tools are authorized for the maintenance of a "B" coded item. However, the item may be reconditioned by adjusting, lubricating, etc., at the user level.

(3) **Recoverability.** Recoverability codes are assigned to items to indicate the disposition action on unserviceable items. The recoverability code is entered in the fifth position of the SMR Code as follows:

Recoverability Codes	Application/Explanation
Z	Nonreparable item. When unserviceable, condemn and dispose of the item at the level of maintenance shown in 3rd position of SMR Code.
O	Reparable item. When not economically repairable, condemn and dispose of the item at unit or AVUM level.
F	Reparable item. When uneconomically repairable, condemn and dispose of the item at the direct support or AVIM level.
H	Reparable item. When uneconomically repairable, condemn and dispose of the item at the general support level.

D - Reparable item. When beyond lower level repair capability, return to depot. Condemnation and disposal of item not authorized below depot level.

L - Reparable item. Condemnation and disposal not authorized below specialized repair activity (SRA).

A - Item requires special handling or condemnation procedures because of specific reasons (e.g., precious metal content, high dollar value, critical material, or hazardous material). Refer to appropriate manuals/directives for specific instructions.

c. CAGEC (Column (3)). The Commercial and Government Entity Code (CAGEC) is a 5-digit numeric code which is used to identify the manufacturer, distributor, or Government agency/activity that supplies the item.

d. PART NUMBER (Column (4)). Indicates the primary number used by the manufacturer, (individual, company, firm, corporation, or Government activity), which controls the design and characteristics of the item by means of its engineering drawings, specifications, standards, and inspection requirements to identify an item or range of items.

NOTE

When you use an NSN to requisition an item, the item you receive may have a different part number from the number listed.

e. DESCRIPTION AND USABLE ON CODE (UOC) (Column (5)). This column includes the following information:

(1) The Federal item name and, when required, a minimum description to identify the item.

(2) The physical security classification of the item is indicated by the parenthetical entry, e.g., Phy Sec C1 (C)-Confidential, Phy Sec C1 (S)-Secret, Phy Sec C1 (T)-Top-Secret.

(3) Items that are included in kits and sets are listed below the name of the kit or set.

(4) Spare/repair parts that make up an assembled item are listed immediately following the assembled item line entry.

(5) Part numbers of bulk materials are referenced in this column in the line entry for the item to be manufactured/fabricated.

(6) When the item is not used with all serial numbers of the same model, the effective serial numbers are shown on the last line(s) of the description (before UOC).

(7) The usable on code, when applicable (reference paragraph 5, Special Information).

(8) In the Special Tools List Section, the basis of issue (BOI) appears as the last line(s) in the entry for each special tool, special TMDE, and other special support equipment. When density of equipment supported exceeds density spread indicated in the basis of issue, the total authorization is increased proportionately.

(9) The statement "END OF FIGURE" appears just below the last item description in Column (5) for a given figure in both Section II and Section III.

(10) The indenture, shown as dots appearing before the repair part, indicates that the item is a repair part of the next higher assembly.

f. **QTY (Column (6)).** The QTY (quantity per figure) column indicates the quantity of the item used in the breakout shown on the illustration/figure, which is prepared for a functional group, subfunctional group, or an assembly. A "V" appearing in this column instead of a quantity indicates that the quantity is variable and may vary from application to application.

4. EXPLANATION OF INDEX FORMAT AND COLUMNS (Section IV).

a. NATIONAL STOCK NUMBER (NSN) INDEX.

(1) **STOCK NUMBER Column.** This column lists the NSN in national item identification number (NIIN) sequence. The NIIN consists of the last nine digits of the NSN, i.e.

NSN
5305-01-574-1467
NIIN

When using this column to locate an item, ignore the first four digits of the NSN. However, the complete NSN should be used when requisitioning items by stock number.

(2) **FIG. Column.** This column lists the number of the figure where the item is identified/located. The figures are in numerical order in Section II and Section III.

(3) **ITEM Column.** The item number identifies the item associated with the figure listed in the adjacent FIG. column. This item is also identified by the NSN listed on the same line.

b. PART NUMBER INDEX. Part numbers in this index are listed in ascending alphanumeric sequence (i. e., vertical arrangement of letter and number combinations which place the first letter or digit of each group in order A through Z, followed by the numbers 0 through 9, and each following letter or digit in like order).

(1) **CAGEC Column.** The Commercial and Government Entity Code (CAGEC) is a 5-digit numeric code used to identify the manufacturer, distributor, or Government agency/activity that supplies the item.

(2) **PART NUMBER Column.** Indicates the primary number used by the manufacturer (individual, firm, corporation, or Government activity), which controls the design

and characteristics of the item by means of its engineering drawings, specifications standards, and inspection requirements to identify an item or range of items

(3) **STOCK NUMBER column.** This column lists the NSN for the associated part number and manufacturer identified in the PART NUMBER and CAGEC columns to the left.

(4) **FIG. column.** This column lists the number of the figure where the item is identified/located in Sections II and III.

(5) **ITEM column.** The item number is that number assigned to the item as it appears in the figure referenced in adjacent figure number column.

c. FIGURE AND ITEM NUMBER INDEX.

(1) **FIG. column.** This column lists the number of the figure where the item is identified/located in Section II and III.

(2) **ITEM column.** The item number is that number assigned to the item as it appears in the figure referenced in the adjacent figure number column.

(3) **STOCK NUMBER column.** This column lists the NSN for the item.

(4) **CAGEC column.** The Commercial and Government Entity Code (CAGEC) is a 5digit numeric code used to identify the manufacturer, distributor, or Government agency, etc., that supplies the item.

(5) **PART NUMBER column.** Indicates the primary number used by the manufacturer (individual, firm, corporation, or Government activity), which controls the design and characteristics of the item by means of its engineering drawings, specifications standards, and inspection requirements to identify an item or range of items.

5. SPECIAL INFORMATION.

a. **USABLE ON CODE.** The usable on code appears in the lower corner of the Description column heading. Usable on codes are shown as "UOC" in the Description Column (justified left) on the last line applicable item description/nomenclature. Uncoded items are applicable to all models.

b. **ASSOCIATED PUBLICATIONS.** The publications listed below pertains to the Filter Separator: Not Applicable.

6. HOW TO LOCATE REPAIR PARTS.

a. When National Stock Number or Part Number is NOT Known.

(1) **First.** Using the table of contents, determine the assembly group or subassembly group to which the item belongs. This is necessary since figures are prepared for assembly groups and subassembly groups, and listings are divided into the same groups.

(2) **Second.** Find the figure covering the assembly group or subassembly group to which the item belongs.

(3) **Third.** Identify the item on the figure and note the item number.

(4) **Fourth.** Refer to the Repair Parts List for the figure to find the part number for the item number noted on the figure.

(5) **Fifth.** Refer to the Part Number Index to find the NSN, if assigned.

b. When National Stock Number or Part Number is Known.

(1) **First.** Using the Index of National Stock Numbers and Part Numbers, find the pertinent National Stock Number or Part Number. The NSN index is in National Item Identification Number (NIIN) sequence (see c-4a.(1)). The part numbers in the Part Number index are listed in ascending alphanumeric sequence (see paragraph c-4.b). Both indexes cross-reference you to the illustration figure and item number of the item you are looking for.

(2) **Second.** After finding the figure and item number, verify that the item is the one you are looking for, then locate the item number in the repair parts list for the figure.

7. ABBREVIATIONS. Abbreviations used in this manual are listed in MIL-STD-12.

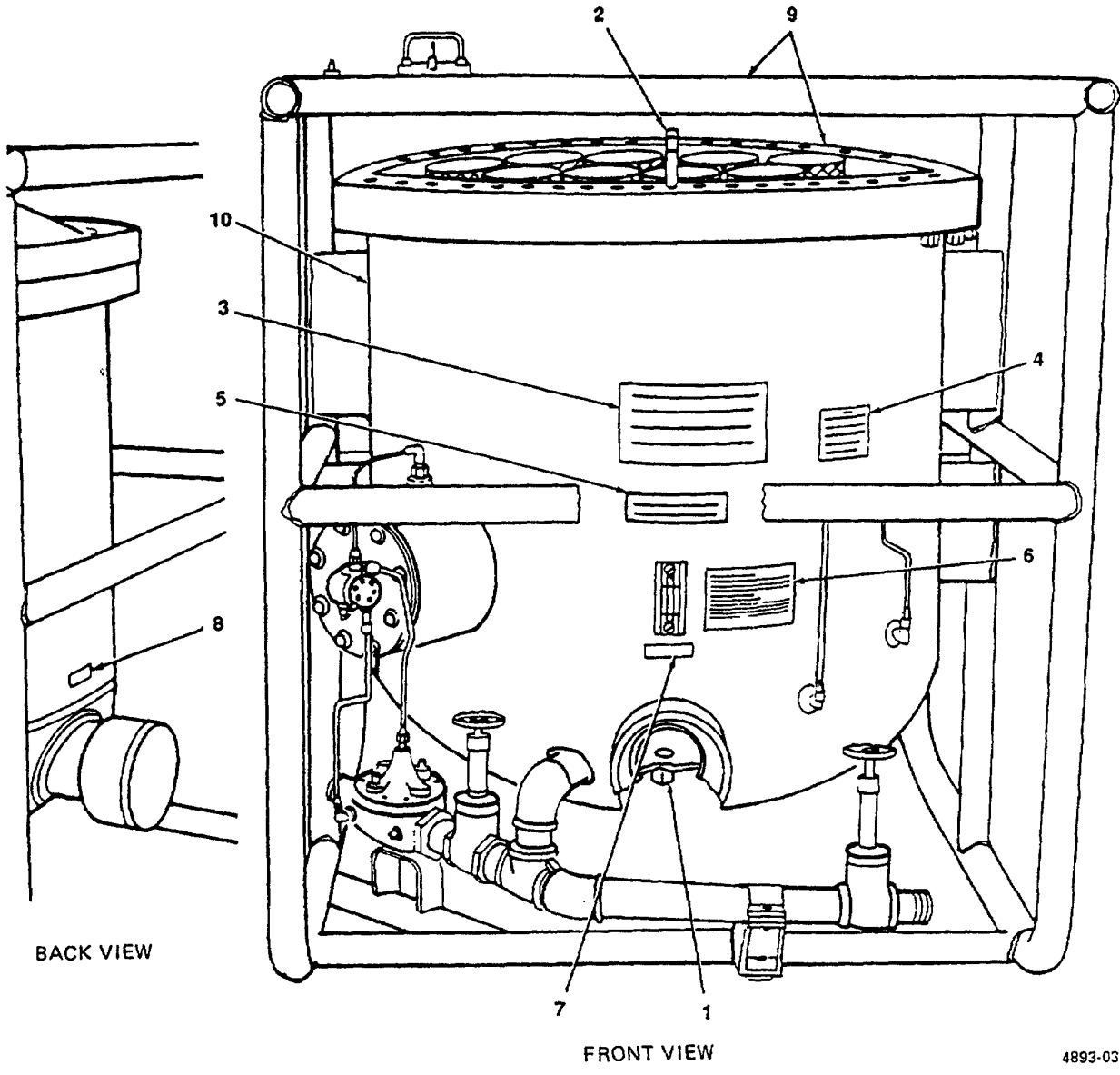

Figure 1. Filter/Separator, Identification and Instruction Plates.

(F-9 blank)/F-10

SECTION II

TM 10-4330-234-13&P

(1) ITEM NO	(2) SMR CODE	(3) CAGEC	(4) PART NUMBER	(5) DESCRIPTION AND USABLE ON CODES (UOC)	(6) QTY
-------------------	--------------------	--------------	-----------------------	--	------------

GROUP 00 FILTER/SEPARATOR

FIG. 1 FILTER, SEPARATOR,
IDENTIFICATION AND
INSTRUCTION PLATES

1	PAOZZ	96906	MS20913-8D	PLUG,PIPE	1
2	PAOZZ	96906	MS16555-680	PIN,STRAIGHT,HEADLE	2
3	XBOZZ	97403	13217E9323	PLATE,INSTRUCTION.....	1
4	XBOZZ	97403	13219E9752	PLATE,INSTRUCTION.....	1
5	XBOZZ	97403	13217E9338	PLATE,INSTRUCTION.....	1
6	XBOZZ	97403	13217E5357-3	PLATE,ID	1
7	XBOZZ	97403	13216E2766	PLATE,INSTRUCTION.....	1
8	XBOZZ	97403	13216E2767	PLATE,INSTRUCTION.....	1
9	XBOZZ	86184	C002201G	NPL BLANK	1
10	XAOFH	97403	13217E9341	TANK,FILTER SEPARATOR.....	1

END OF FIGURE

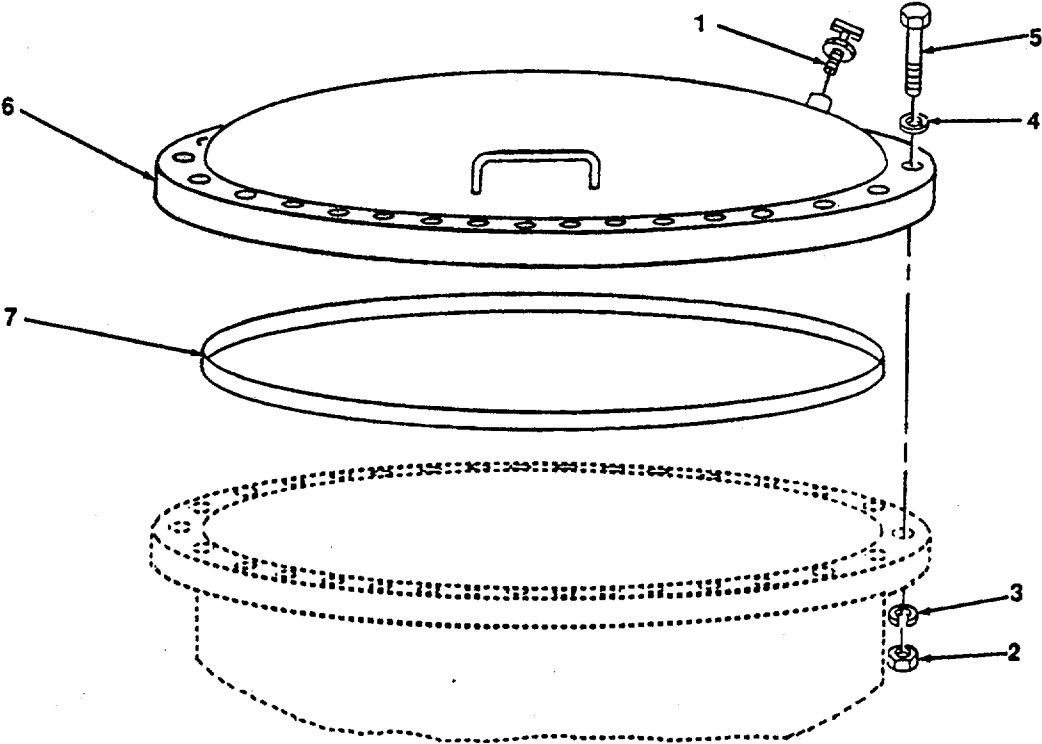

Figure 2. Safety Relief Valve and Tank Cover.
F-12

SECTION II

TM 10-4330-234-13&P

(1) ITEM NO	(2) SMR CODE	(3) CAGEC	(4) PART NUMBER	(5) DESCRIPTION AND USABLE ON CODES (UOC)	(6) QTY
-------------------	--------------------	--------------	-----------------------	--	------------

GROUP 01 COVER ASSEMBLY

FIG. 2 SAFETY RELIEF VALVE AND TANK COVER

1	PAOZZ	44266	2D200A	VALVE,SAFETY RELIEF.....	1
2	PAOZZ	96906	MS51968-20	NUT,PLAIN,HEXAGON.....	30
3	XDOZZ	96906	MS35338	WASHER,LOCK.....	30
4	PAOZZ	96906	MS27183-21	WASHER,FLAT.....	30
5	PAOZZ	96906	MS90726-174	SCREW,CAP,HEXAGONH	30
6	XBOZZ	97403	13217E9342	COVERTANK F/S	1
7	PAOZZ	97403	13217E9325-2	PACKING PREFORMED.....	1

END OF FIGURE

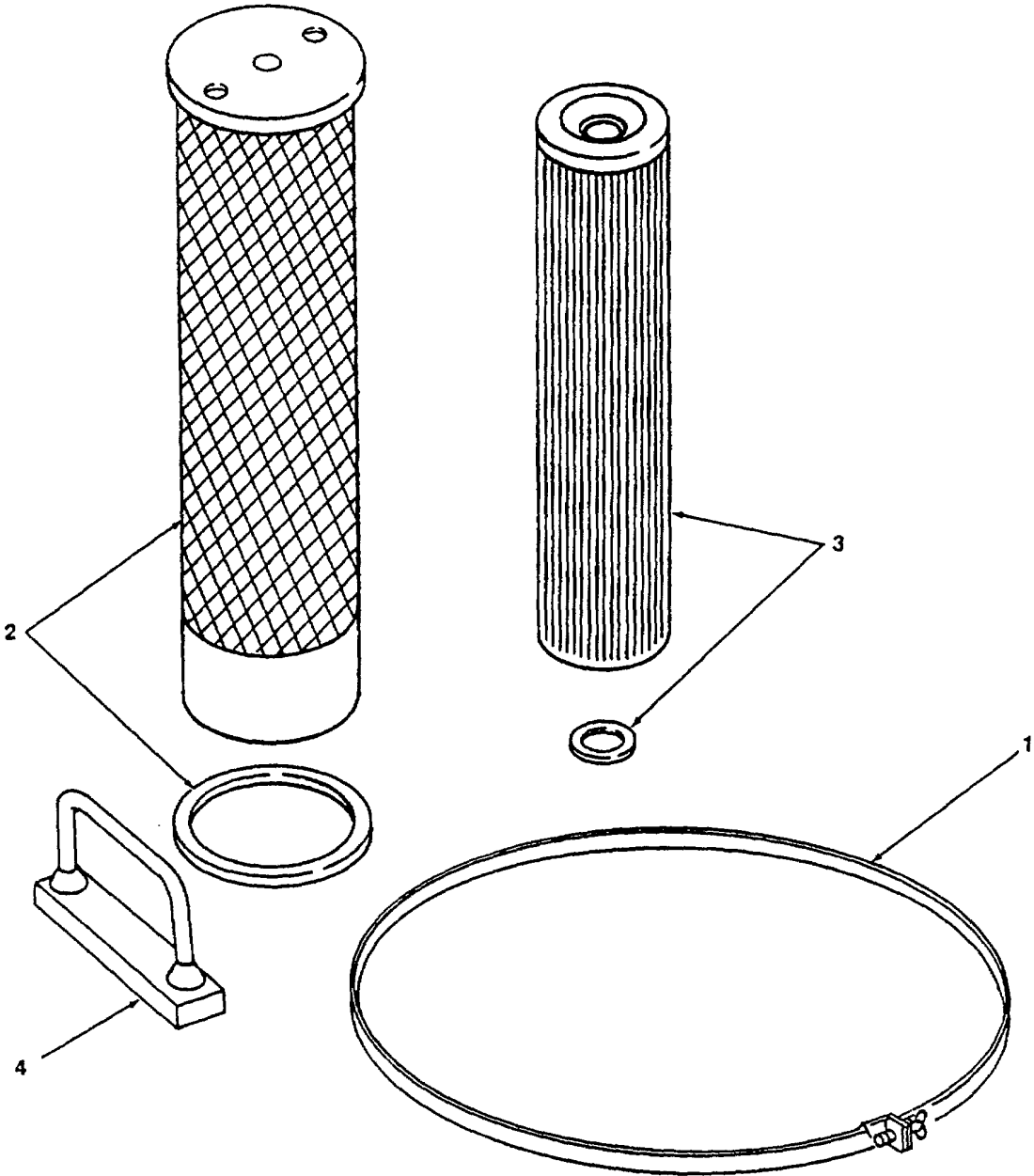

4893-029

Figure 3. Cannister, Clamp Band, and Filter Element.
F-14

SECTION II

TM 10-4330-234-13&P

(1) ITEM NO	(2) SMR CODE	(3) CAGEC	(4) PART NUMBER	(5) DESCRIPTION AND USABLE ON CODES (UOC)	(6) QTY
-------------------	--------------------	--------------	-----------------------	--	------------

GROUP 02 CANNISTER, CLAMP BAND, AND
FILTER ELEMENT

FIG. 3 CLAMP BAND, WRENCH,
CANNISTER, AND FILTER
ELEMENT

1	PAOZZ	97403	13216E2789-7	CLAMP,HOSE.....	1
2	PAOZZ	97403	13217E5368	CANISTER.....	30
3	PAOZZ	81349	MIL-F-52308	FILTER ELEMENT,FLUI.	30
4	PAOFF	97403	13217E5367	WRENCH,SPANNER.....	1

END OF FIGURE

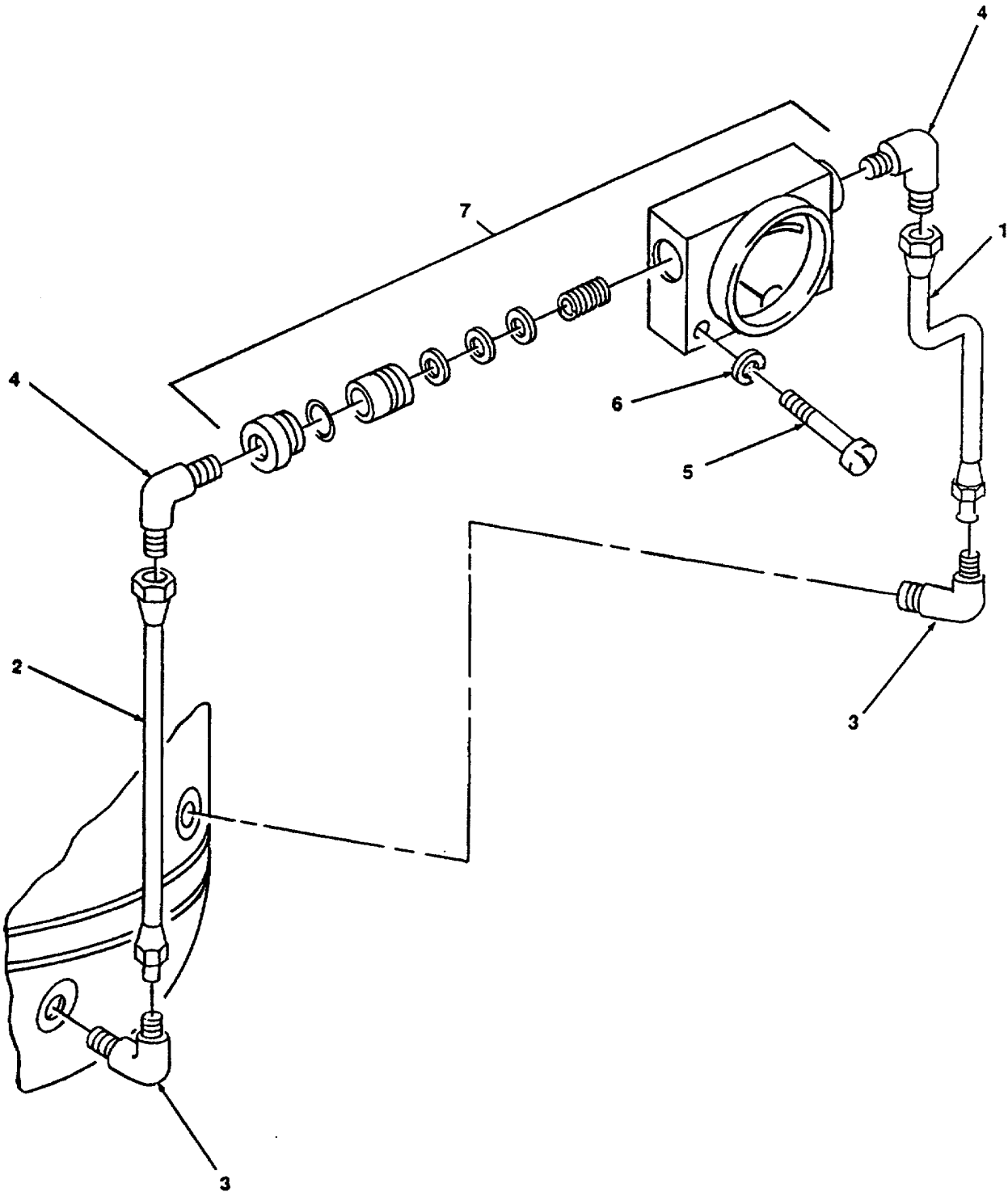

4893-030

Figure 4. Differential Pressure Gage.

SECTION II

TM 10-4330-234-13&P

(1) ITEM NO	(2) SMR CODE	(3) CAGEC	(4) PART NUMBER	(5) DESCRIPTION AND USABLE ON CODES (UOC)	(6) QTY
				GROUP 03 GAGES,MOUNTING LINES AND FITTINGS	
				FIG. 4 DIFFERENTIAL PRESSURE GAGE	
1	PAOZZ	97403	13217E5365-4	TUBE ASSEMBLY,METAL.....	1
2	PAOZZ	97403	13217E5365-4	TUBE ASSEMBLY,METAL.....	1
3	PAOZZ	96906	MS20822-5-4D	ELBOW,PIPE TO TUBE.....	2
4	PAOZZ	96906	MS20822-5D	ELBOW,PIPE TO TUBE 90 DEGREE	1
5	PAOZZ	96906	MS51957-85	SCREW,MACHINE	2
6	PAOZZ	96906	MS35338-44	WASHER,LOCK.....	2
7	PAOOZ	30839	1201 PG-2-2	GAGE, DIFFERENTIAL,D	1

END OF FIGURE

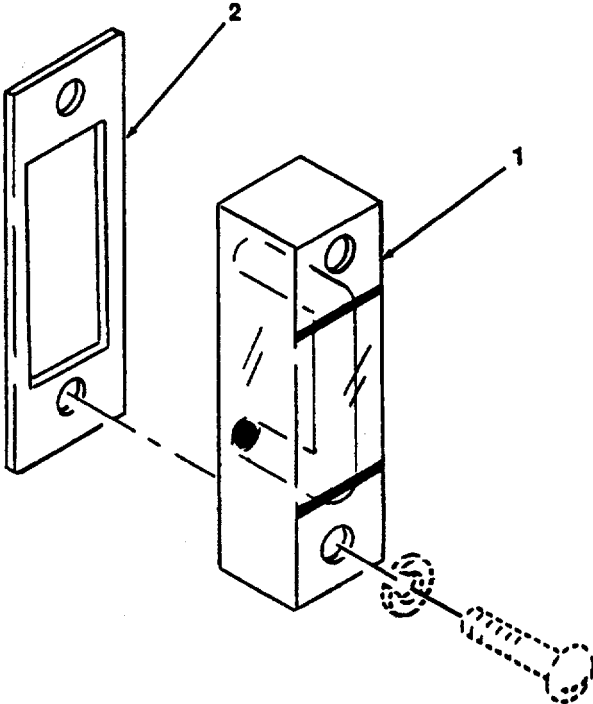

Figure 5. Sight Gage.
F-18

SECTION II

TM 10-4330-234-13&P

(1) ITEM NO	(2) SMR CODE	(3) CAGEC	(4) PART NUMBER	(5) DESCRIPTION AND USABLE ON CODES (UOC)	(6) QTY
-------------------	--------------------	--------------	-----------------------	--	------------

GROUP 03 GAGES, MOUNTING LINES AND FITTINGS

FIG. 5 SIGHT GAGE

1	PADZZ	97403	13217E9367	GAGE,SIGHT,WATER VEL	1
2	XBOZZ	81346	ASTM-D2000	RUBBER PRODUCT	1

END OF FIGURE

4
5 THRU 16

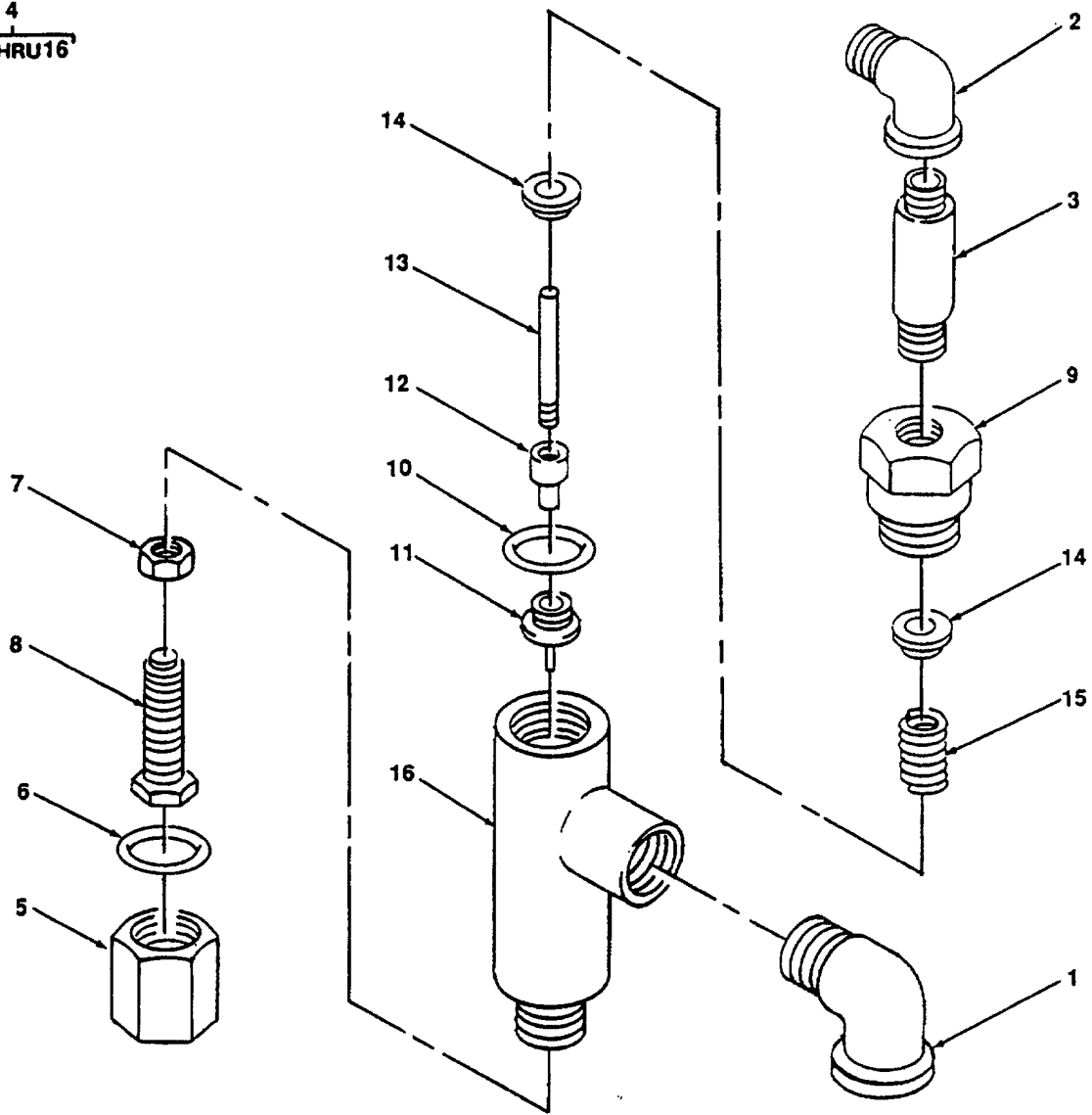

4893-032

Figure 6. Pressure Relief Valve.
F-20

SECTION II

TM 10-4330-234-13&P

(1) ITEM NO	(2) SMR CODE	(3) CAGEC	(4) PART NUMBER	(5) DESCRIPTION AND USABLE ON CODES (UOC)	(6) QTY
				GROUP 04 VALVES AND LINES	
				FIG. 6 PRESSURE RELIEF VALVE	
1	PAOZZ	97403	13218E0423-5	ELBOW,PIPE.....	1
2	PAOZZ	88044	AN914-4D	ELBOW,PIPE.....	1
3	XBOZZ	81349	MILP25995AALY606 1-T6SCH40.5X3INL	PIPE,THD,BOTH ENDS.....	1
4	PAOFZ	34494	FIG 171-S1/2SIZE	VALVE PRESSURE RELIEF.....	1
5	XBOZZ	34494	A13639.001.102	HOOD.....	1
6	XDOZZ	34494	A6486.020.142	GASKET.....	1
7	XBOZZ	34494	A6482.021.102	SCREW,PRESS,L'NUT.....	1
8	XBOZZ	34494	A13268.008.102	PRESS SCREW.....	1
9	XBOZZ	34494	B13110.002.171	CAP.....	1
10	XDOZZ	34494	A6486.033.142	GASKET.....	1
11	XDOZZ	34494	B3985.001.274	DISC.....	1
12	XBOZZ	34494	A10648.001.102	STEM END.....	1
13	XBOZZ	34494	A6471.028.102	STEM.....	2
14	XBOZZ	34494	A6481.019.102	PLATE,SPRING.....	2
15	XBOZZ	34494	A13613	SPRING.....	1
16	XAOZZ	34494	A6765-001	BODY.....	1

END OF FIGURE

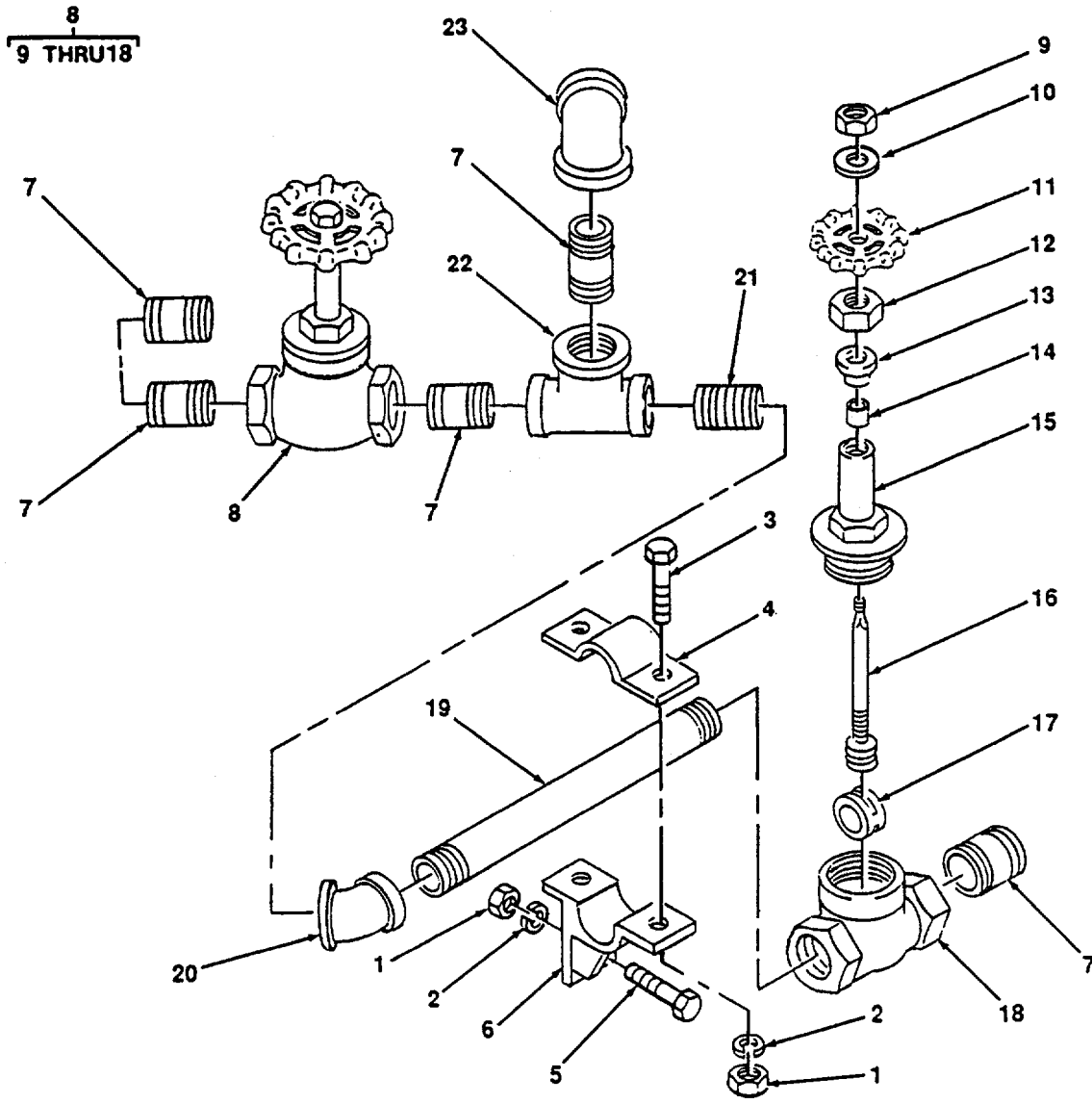

4893-033

Figure 7. Manual Drain/Isolation Valve.

SECTION II

TM 10-4330-234-13&P

(1) ITEM NO	(2) SMR CODE	(3) CAGEC	(4) PART NUMBER	(5) DESCRIPTION AND USABLE ON CODES (UOC)	(6) QTY
GROUP 04 VALVES AND LINES					
FIG. 7 MANUAL DRAIN/ISOLATION VALVE					
1	PAOZZ	96906	MS51967-2	NUT,PLAIN,HEXAGON.....	4
2	PAOZZ	96906	MS35338-44	WASHER,LOCK.....	4
3	XDOZZ	96906	MS24693-5	SCREW,MACHINE STY 95 TY1 CD PLD 1/.....	2
4	XBOZZ	97403	13217E5364	4-20UNC-2AX1.50 L. CLAMP SUPPORT.....	1
5	PAOZZ	96906	MS90725-7	SCREW,CAP,HEXAGON H.....	4
6	XBOZZ	97403	13217E5359	BRACKET,SUPPORT.....	1
7	XBOZZ	81349	MILP25995A 61-T6SCH4011/2	ALY60 PIPE,THD BOTH ENDS 1.5INX14INLG.....	5
8	PAOFZ	14448	FIG690-11/2SIZE	VALVE,GATE CL B STY 1 TYIII.....	2
9	XBOZZ	14448	3229	NUT,HANDWHEEL.....	1
10	XBOZZ	14448	9877	PLATE,ID.....	1
11	XBOZZ	14448	9752-K	HANDWHEEL.....	1
12	PAOZZ	14448	937	PACKING NUT.....	1
13	XBOZZ	14448	7939	GLAND FOLLOWER.....	1
14	XDOZZ	14448	5893	PACKING, PREFORMED.....	1
15	XBOZZ	14448	11460	BONNET.....	1
16	XBOZZ	14448	11461	STEM,VALVE.....	1
17	XBOZZ	14448	9559	DISC.....	1
18	XAOZZ	14448	11459	BODY,VALVE.....	2
19	XBOZZ	81349	MILP25995A ALY60 61-T6SCH4011/2	PIPE,THD,BOTH ENDS,1.5 2.38 IN.....	5
20	PAOZZ	81349	M52618/5B08XA	LG. ELBOW, PIPE.....	1
21	XBOZZ	81349	MILP25995AALY606 1-T6SCH40-1-1-2	NIPPLE,CLOSE, 1.5X1.75IN LG.....	1
22	PAOZZ	97403	13218E0416-8	TEE,PIPE.....	1
23	PAOZZ	97403	13218E0415-8	ELBOW,PIPE.....	1

END OF FIGURE

4
5 THRU 21

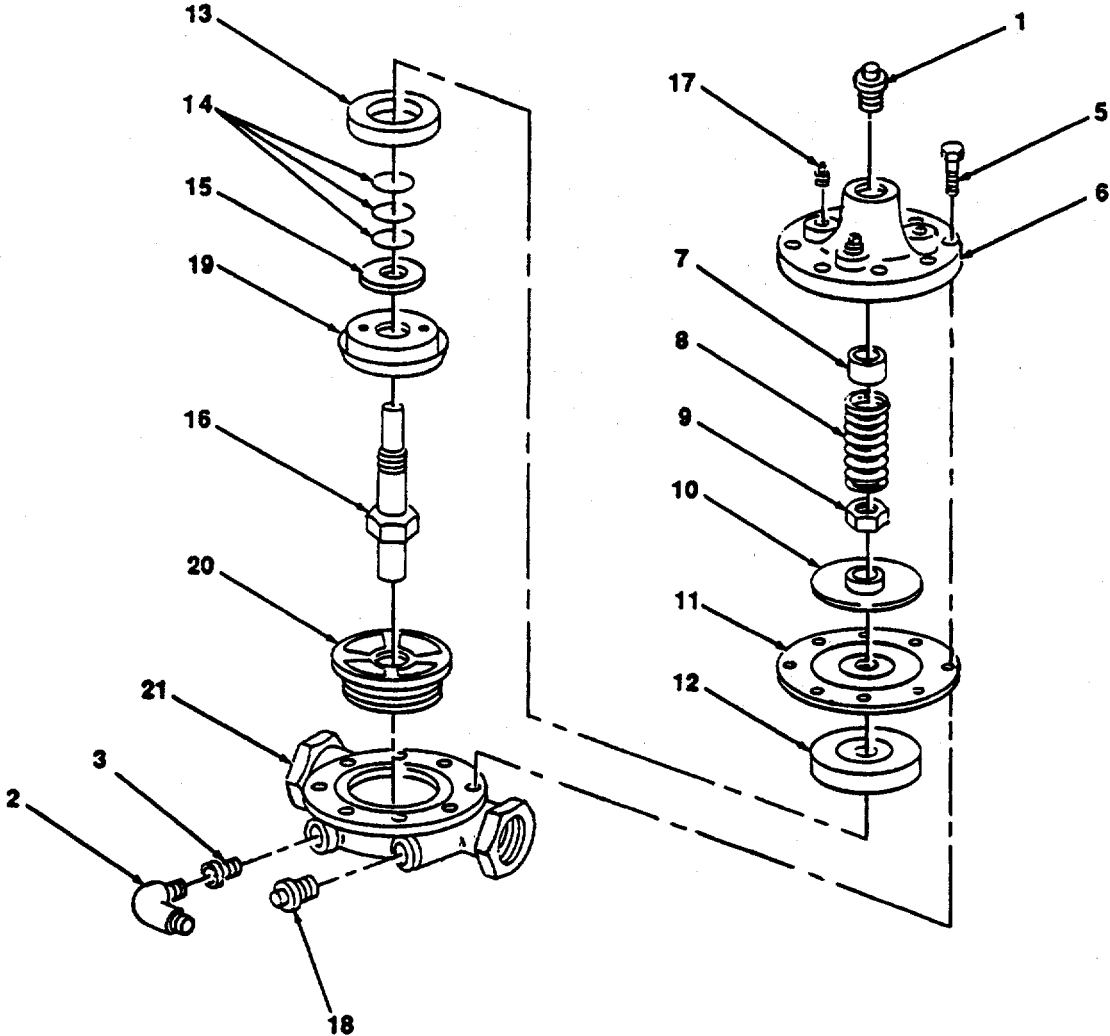

Figure 8. Automatic Drain Valve.

SECTION II

TM 10-4330-234-13&P

(1) ITEM NO	(2) SMR CODE	(3) CAGEC	(4) PART NUMBER	(5) DESCRIPTION AND USABLE ON CODES (UOC)	(6) QTY
GROUP 04 VALVES AND LINES					
FIG. 8 AUTOMATIC DRAIN VALVE					
1	PAOZZ	81352	AN816-5-4D	ADAPTER,STRAIGHT,PI PIPE TO TUBE	1
2	PAOZZ	96906	MS20822-5-4D	ELBOW,PIPE TO TUBE 90 DEGREE 5/16	2
TUBING OD ¼ ANPTX1/2-20 UNJF-3A					
AL ALY					
3	PAOZZ	88044	AN912-2D	BUSHING,PIPE	1
4	XDOOO	96906	13217E9344-2	VALVE,WATER DRAIN	1
5	XDOZZ	86184	6760427C	BOLT	8
6	XBFZZ	86184	C7517A	COVER,100	1
7	XBFZZ	86184	C7521C	BEARING, COVER, 100	1
8	XBOZZ	86184	C8477G	SPRING, 100	1
9	XDOZZ	86184	8937501J	NUT,STEM	1
10	XDFZZ	86184	V5398C	WASHER,DIAPHRAM	1
11	XBFZZ	86184	83239E	DIAPH 100	1
12	XBOZZ	86184	V5399A	RETAINER,DISC,100	1
13	PAFZZ	86184	V5562D	DISK,VALVE	1
14	PAFZZ	86184	V5180E	WASHER	2
15	XBOZZ	86184	V1393H	GUIDE,DISC 100	1
16	XBOZZ	86184	V1388H	STEM,100	1
17	PAFZZ	96906	MS520913-2D	PLUG PIPE HXH1/4IN	3
18	PAFZZ	96906	MS14314-3X	PLUG,PIPE	4
19	XBOZZ	86184	V1391B	SEAT,100	1
20	XDFZZ	86184	00731A	PACKING,PREFORMED	1
21	XAFZZ	86184	C7553F	BODY,100	1

END OF FIGURE

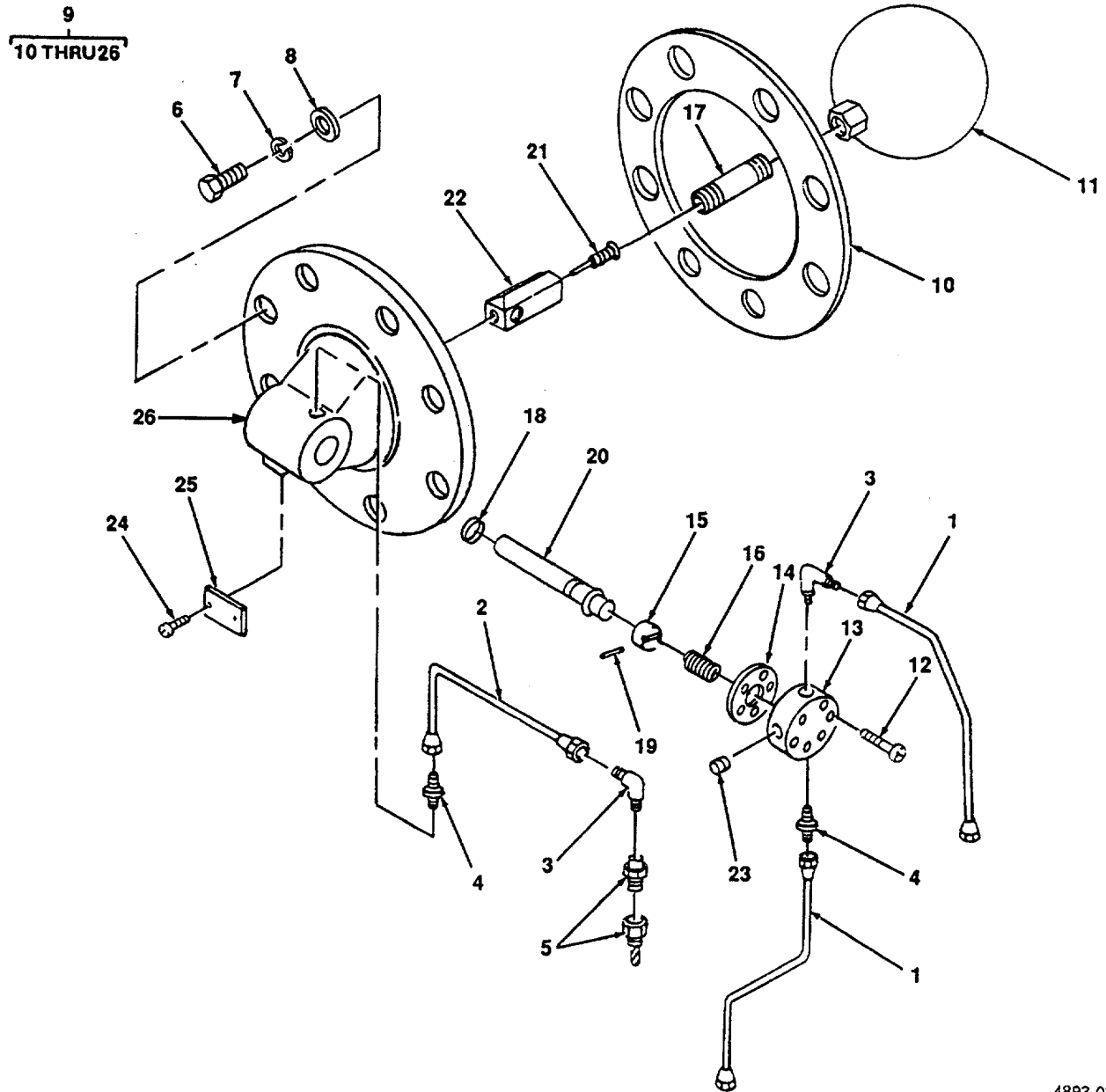

4893-035

Figure 9. Float Control Valve.

SECTION II

TM 10-4330-234-13&P

(1) ITEM NO	(2) SMR CODE	(3) CAGEC	(4) PART NUMBER	(5) DESCRIPTION AND USABLE ON CODES (UOC)	(6) QTY
-------------------	--------------------	--------------	-----------------------	--	------------

GROUP 04 VALVES AND LINES

FIG. 9 FLOAT CONTROL VALVE

1	XDOZZ	97403	13217E5365-5	TUBE ASSEMBLY,METAL.....	2
2	XDOZZ	97403	13217E5365-8	TUBE ASSEMBLY,METAL.....	1
3	PAOZZ	96906	MS20822-5D	ELBOW,PIPE TO TUBE 90 DEGREE	2
4	PAOZZ	88044	AN816-5D	ADAPTER,STRAIGHT PIPE TO TUBE	2
5	PAOZZ	86184	C-7499	STRAINER	1
6	PAOZZ	96906	MS90728-87	SCREW,CAP,HEXAGON H7/16-14X11/4.....	8
7	PAOZZ	96906	MS35338-47	WASHER,LOCK.....	8
8	PAOZZ	96906	MS27183-16	WASHER,FLAT.....	8
9	PAOZF	86184	68266	VALVE,FLOAT	1
10	PAOZZ	86184	C5920	GASKET	1
11	PAOZZ	86184	31925	FLOAT,VALVE	1
12	PAOZZ	96906	MS9123-09	SCREW,MACHINE	6
13	XBOZZ	86184	68755	DISTRIBUTOR.....	1
14	PAOZZ	86184	C19	GASKET	1
15	XBOZZ	86184	68757	DISC	1
16	XBOZZ	86184	TV220	SPRING,HELICAL,COMP	1
17	XBOZZ	86184	68965	STEM ASSEMBLY	1
18	XDOZZ	86184	00901	PACKING,PREFORMED.....	1
19	XBOZZ	86184	68961	PIN LOCATING	1
20	PAOZZ	96906	MS51873-3	NIPPLE,PIPE	1
21	XBOZZ	86184	C2054	PIN,LOCK	1
22	XBOZZ	86184	C5085	ARM FLOAT.....	1
23	PAOZZ	96906	MS14314-2X	PLUG,PIPE	1
24	XBOZZ	86184	67999	SCREW,DRIVE.....	2
25	XBOZZ	86184	C22	NAME PLATE	1
26	XAOZZ	86184	68201	HOUSING,FLOAT.....	1

END OF FIGURE

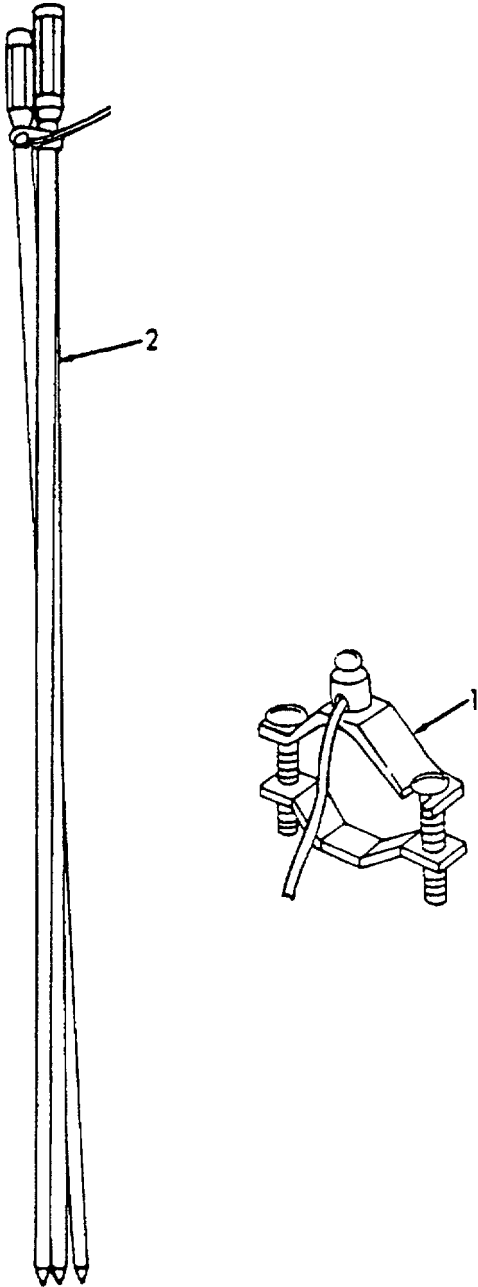

Figure 10. Ground Rods.

SECTION II

TM 10-4330-234-13&P

(1) ITEM NO	(2) SMR CODE	(3) CAGEC	(4) PART NUMBER	(5) DESCRIPTION AND USABLE ON CODES (UOC)	(6) QTY
-------------------	--------------------	--------------	-----------------------	--	------------

GROUP 05 GROUNDING ASSEMBLY

FIG. 10 GROUND RODS

1	XDOZZ	98245	690521	CLAMP, ELECTRICAL	1
2	XBOZZ	81348	W-R-550	ROD, CL B, TY III.....	1

END OF FIGURE

F-29/(F-30 Blank)

SECTION III. SPECIAL TOOLS LIST

(Not Applicable)

F-31/(F-32 Blank)

**CROSS-REFERENCE INDEXES
NATIONAL STOCK NUMBER INDEX**

STOCK NUMBER	FIG.	ITEM	STOCK NUMBER	FIG.	ITEM
4730-00-011-2304	F-8	18			
4730-00-011-2578	F-9	23			
5305-00-071-1788	F-9	6			
5305-00-071-2088	F-4	5			
5305-00-082-6986	F-9	12			
5330-00-112-1304	F-9	10			
4820-00-113-5527	F-9	9			
4730-00-187-0088	F-9	4			
4730-00-187-1387	F-6	2			
5310-00-209-0965	F-9	7			
4730-00-223-7074	F-8	3			
4730-00-223-9260	F-1	1			
5305-00-225-3840	F-7	5			
4730-00-278-3678	F-4	4			
	F-9	3			
4730-00-278-4684	F-4	3			
	F-8	2			
5330-00-312-2545	F-9	14			
4730-00-436-7307	F-9	20			
5310-00-582-5965	F-4	6			
	F-7	2			
5305-00-725-4152	F-2	5			
5310-00-761-6882	F-7	1			
5310-00-763-8905	F-2	2			
4820-00-803-9559	F-9	11			
5310-00-809-4085	F-9	8			
5310-00-823-8803	F-2	4			
6685-01-015-8645	F-4	7			
5315-01-062-3502	F-1	2			
4710-01-068-1587	F-4	1			
	F-4	2			
4820-01-109-3345	F-8	13			
4330-01-117-1753	F-3	2			
6680-01-117-7230	F-5	1			
5330-01-119-7639	F-2	7			
4820-01-121-6402	F-6	4			
4730-01-121-9477	F-9	5			
4730-01-128-9085	F-7	23			
4730-01-129-5162	F-6	1			
4730-01-161-3987	F-7	22			
5310-01-200-1100	F-8	14			
4730-01-210-0337	F-7	20			
4730-01-229-6253	F-3	1			
5120-01-239-2256	F-3	4			
4730-01-251-6495	F-7	12			

CROSS-REFERENCE INDEXES

CAGEC	PART NUMBER	PART NUMBER INDEX STOCK NUMBER	FIG.	ITEM
81352	AN816-5-4D		F-8	1
88044	AN816-5D	4730-00-187-0088	F-9	4
88044	AN912-2D	4730-00-223-7074	F-8	3
88044	AN914-4D	4730-00-187-1387	F-6	2
81346	ASTM-D2000		F-5	2
34494	A10648.001.102		F-6	12
34494	A13268.008.102		F-6	8
34494	A13613		F-6	15
34494	A13639.001.102		F-6	5
34494	A6471.028.102		F-6	13
34494	A6481.019.102		F-6	14
34494	A6482.021.102		F-6	7
34494	A6486.020.142		F-6	6
34494	A6486.033.142		F-6	10
34494	A6765-001		F-6	16
34494	B13110.002.171		F-6	9
34494	B3985.001.274		F-6	11
86184	C-7499	4730-01-121-9477	F-9	5
86184	C002201G		F-1	9
86184	C19	5330-00-312-2545	F-9	14
86184	C2054		F-9	21
86184	C22		F-9	25
86184	C5085		F-9	27
86184	C5920	5330-00-112-1304	F-9	1
86184	C7517A		F-8	10
86184	C7521C		F-8	7
86184	C7553F		F-8	21
86184	C8477G		F-8	8
34494	FIG 171-S1/2SIZE	4820-01-121-6402	F-6	4
14448	FIG690-11/2SIZE		F-7	8
81349	MIL-F-52308		F-3	3
81349	MILP25995A ALY60 61-T6SCH4011/2		F-7	7
			F-7	19
81349	MILP25995AALY606 1-T6SCH40.5X3INL		F-6	3
81349	MILP25995AALY606 61-T6SCH40-1-1-2		F-7	21
96906	MS14314-2X	4730-00-011-2578	F-9	23
96906	MS14314-3X	4730-00-011-2304	F-8	18
96906	MS16555-680	5315-01-062-3502	F-1	2
96906	MS20822-5-4D	4730-00-278-4684	F-4	3
			F-8	2
96906	MS20822-5D	4730-00-278-3678	F-4	3
			F-9	3
96906	MS20913-8D	4730-00-223-9260	F-1	1
96906	MS24693-5		F-7	3
96906	MS27183-16	5310-00-809-4085	F-9	8
96906	MS27183-21	5310-00-823-8803	F-2	4
96906	MS35338		F-2	3
96906	MS35338-44	5310-00-582-5965	F-4	6

CROSS-REFERENCE INDEXES

CAGEC	PART NUMBER	PART NUMBER INDEX		FIG.	ITEM
			STOCK NUMBER		
96906	MS35338-44		5310-00-582-5965	F-7	2
96906	MS35338-47		5310-00-209-0965	F-9	7
96906	MS51873-3		4730-00-436-7307	F-9	20
96906	MS51957-85		5305-00-071-2088	F-4	5
96906	MS51967-2		5310-00-761-6882	F-7	1
96906	MS51968-20		5310-00-763-8905	F-2	2
96906	MS520913-2D			F-8	17
96906	MS90725-7		5305-00-225-3840	F-7	5
96906	MS90726-174		5305-00-725-4152	F-2	5
96906	MS90728-87		5305-00-071-1788	F-9	6
96906	MS9123-09		5305-00-082-6986	F-9	12
81349	M52618/5B08XA		4730-01-210-0337	F-7	20
86184	TV220			F-9	16
86184	V1388H			F-8	16
86184	V1391B			F-8	19
86184	V1393H			F-8	15
86184	V5180E		5310-01-200-1100	F-8	14
86184	V5398C			F-8	10
86184	V5399A			F-8	12
86184	V5562D		4820-01-109-3345	F-8	13
81348	W-R-550			F-10	2
86184	00731A			F-8	20
86184	00901			F-9	18
14448	11459			F-7	18
14448	11460			F-7	15
14448	11461			F-7	16
30839	1201 PG-2-2		6685-01-015-8645	F-4	7
97403	13216E2766			F-1	7
97403	13216E2767			F-1	8
97403	13216E2789-7		4730-01-229-6253	F-3	1
97403	13217E5357-3			F-1	6
97403	13217E5359			F-7	6
97403	13217E5364			F-7	4
97403	13217E5365-4		4710-01-068-1587	F-4	1
				F-4	2
97403	13217E5365-5			F-9	2
97403	13217E5365-8			F-9	2
97403	13217E5367		5120-01-239-2256	F-3	4
97403	13217E5368		4330-01-117-1753	F-3	2
97403	13217E9323			F-1	3
97403	13217E9325-2		5330-01-119-7639	F-2	7
97403	13217E9338			F-1	5
97403	13217E9341			F-1	10
97403	13217E9342			F-2	6
96906	13217E9344-2			F-8	4
97403	13217E9367		6680-01-117-7230	F-5	1
97403	13218E0415-8		4730-01-128-9085	F-7	23
97403	13218E0416-8		4730-01-161-3987	F-7	22
97403	13218E0423-5		4730-01-129-5162	F-6	1
97403	13219E9752			F-1	4
44266	2D200A			F-2	1

CROSS-REFERENCE INDEXES

CAGEC	PART NUMBER	PART NUMBER INDEX STOCK NUMBER	FIG.	ITEM
86184	31925	4820-00-803-9559	F-9	11
14448	3229		F-7	9
14448	5893		F-7	14
86184	6760427C		F-8	5
86184	67999		F-9	24
86184	68201		F-9	26
86184	68266	4820-00-113-5527	F-9	9
86184	68755		F-9	13
86184	68757		F-9	15
86184	68961		F-9	19
86184	68965		F-9	17
98245	690521		F-10	1
14448	7939		F-7	13
86184	83239E		F-8	11
86184	8937501J		F-8	9
14448	937	4730-01-251-6495	F-7	12
14448	9559		F-7	17
14448	9752-K		F-7	11
14448	9877		F-7	10

CROSS-REFERENCE INDEXES

FIGURE AND ITEM NUMBER INDEX

FIG.	ITEM	STOCK NUMBER	CAGEC	PART NUMBER
F-1	1	4730-00-223-9260	96906	MS20913-8D
F-1	2	5315-01-062-3502	96906	MS16555-680
F-1	3		97403	13217E9323
F-1	4		97403	13219E9752
F-1	5		97403	13217E9338
F-1	6		97403	13217E5357-3
F-1	7		97403	13216E2766
F-1	8		97403	13216E2767
F-1	9		86184	C002201G
F-1	10		97403	13217E9341
F-2	1		44266	2D200A
F-2	2	5310-00-763-8905	96906	MS51968-20
F-2	3		96906	MS35338
F-2	4	5310-00-823-8803	96906	MS27183-21
F-2	5	5305-00-725-4152	96906	MS90726-174
F-2	6		97403	13217E9342
F-2	7	5330-01-119-7639	97403	13217E9325-2
F-3	1	4730-01-229-6253	97403	13216E2789-7
F-3	2	4330-01-117-1753	97403	13217E5368
F-3	3		81349	MIL-F-52308
F-3	4	5120-01-239-2256	97403	13217E5367
F-4	1	4710-01-068-1587	97403	13217E5365-4
F-4	2	4710-01-068-1587	97403	13217E5365-4
F-4	3	4730-00-278-4684	96906	MS20822-5-4D
F-4	4	4730-00-278-3678	96906	MS20822-5D
F-4	5	5305-00-071-2088	96906	MS51957-85
F-4	6	5310-00-582-5965	96906	MS35338-44
F-4	7	6685-01-015-8645	30839	1201 PG-2-2
F-5	1	6680-01-117-7230	97403	13217E9367
F-5	2		81346	ASTM-D2000
F-6	1	4730-01-129-5162	97403	13218E0423-5
F-6	2	4730-00-187-1387	88044	AN914-4D
F-6	3		81349	MILP2599SAALY606 1-T6SCH40.5X3INL
F-6	4	4820-01-121-6402	34494	FIG 171-S1/2SIZE
F-6	5		34494	A13639.001.102
F-6	6		34494	A6486.020.142
F-6	7		34494	A6482.021.102
F-6	8		34494	A13268.008.102
F-6	9		34494	B13110.002.171
F-6	10		34494	A6486.033.142
F-6	11		34494	B3985.001.274
F-6	12		34494	A10648.001.102
F-6	13		34494	A6471.028.102
F-6	14		34494	A6481.019.102
F-6	15		34494	A13613
F-6	16		34494	A6765-001
F-7	1	5310-00-761-6882	96906	MS51967-2
F-7	2	5310-00-582-5965	96906	MS35338-44
F-7	3		96906	MS24693-5
F-7	4		97403	13217E5364

CROSS-REFERENCE INDEXES

FIGURE AND ITEM NUMBER INDEX

FIG.	ITEM	STOCK NUMBER	CAGEC	PART NUMBER
F-7	5	5305-00-225-3840	96906	MS90725-7
F-7	6		97403	13217E5359
F-7	7		81349	MILP25995A ALY60 v 61-T6SCH4011/2
F-7	8		14448	FIG690-11/2SIZE
F-7	9		14448	3229
F-7	10		14448	9877
F-7	11		14448	9752-K
F-7	12	4730-01-251-6495	14448	937
F-7	13		14448	7939
F-7	14		14448	5893
F-7	15		14448	11460
F-7	16		14448	11461
F-7	17		14448	9559
F-7	18		14448	11459
F-7	19		81349	MILP25995A ALY60 61-T6SCH4011/2
F-7	20	4730-01-210-0337	81349	M52618/5BC8XA
F-7	21		81349	MILP25995AALY606 1-T6SCH40-1-1-2
F-7	22	4730-01-161-3987	97403	13218E0416-8
F-7	23	4730-01-128-9085	97403	13218E0415-8
F-8	1		81352	AN816-5-4D
F-8	2	4730-00-278-4684	96906	MS20822-5-4D
F-8	3	4730-00-223-7074	88044	AN912-2D
F-8	4		96906	13217E9344-2
F-8	5		86184	6760427C
F-8	6		86184	C7517A
F-8	7		86184	C7521C
F-8	8		86184	C8477G
F-8	9		86184	8937501J
F-8	10		86184	V5398C
F-8	11		86184	83239E
F-8	12		86184	V5399A
F-8	13	4820-01-109-3345	86184	V5562D
F-8	14	5310-01-200-1100	86184	V5180E
F-8	15		86184	V1393H
F-8	16		86184	V1388H
F-8	17		96906	MS520913-2D
F-8	18	4730-00-011-2304	96906	MS14314-3X
F-8	19		86184	V1391B
F-8	20		86184	00731A
F-8	21		86184	C7553F
F-9	1		97403	13217E5365-5
F-9	2		97403	13217E5365-8
F-9	3	4730-00-278-3678	96906	MS20822-5D
F-9	4	4730-00-187-0088	88044	AN816-5D
F-9	5	4730-01-121-9477	86184	C-7499
F-9	6	5305-00-071-1788	96906	MS90728-87
F-9	7	5310-00-209-0965	96906	MS35338-47
F-9	8	5310-00-809-4085	96906	MS27183-16

CROSS-REFERENCE INDEXES

FIGURE AND ITEM NUMBER INDEX

FIG.	ITEM	STOCK NUMBER	CAGEC	PART NUMBER
F-9	9	4820-00-113-5527	86184	68266
F-9	10	5330-00-112-1304	86184	C5920
F-9	11	4820-00-803-9559	86184	31925
F-9	12	5305-00-082-6986	96906	MS9123-09
F-9	13		86184	68755
F-9	14	5330-00-312-2545	86184	C19
F-9	15		86184	68757
F-9	16		86184	TV220
F-9	17		86184	68965
F-9	18		86184	00901
F-9	19		86184	68961
F-9	20	4730-00-436-7307	96906	MS51873-3
F-9	21		86184	C2054
F-9	22		86184	C5085
F-9	23	4730-00-011-2578	96906	MS14314-2X
F-9	24		86184	67999
F-9	25		86184	C22
F-9	26		86184	68201
F-10	1		98245	690521
F-10	2		81348	W-R-550

F-39/(F-40 Blank)

INDEX

Subject	Paragraph
A	
Appendices:	
A - References	A-1
B - Maintenance Allocation Chart	B-1
C - Components of End Item and Basic Issue Items	C-1
D - Additional Authorization List	D-1
E - Expendable/Durable Supplies and Material List	E-1
F - Repair Parts and Special Tools List	F-1
Assembly,	
Cover	4-12
Grounding	4-21
Automatic Drain Valve.....	4-19
B	
C	
Clamp Band.....	4-13
Common Tools	4-1
Cover Assembly	4-12
D	
Description and Use of Operator's Controls and Indicators.....	2-2
Destruction of Army Material to Prevent Enemy Use	1-4
Differential Pressure Gage.....	4-15
E	
Element, Filter	4-14
Equipment Characteristics, Capabilities and Features.....	1-7
Equipment Data.....	1-9
F	
Filter Canister	4-14
Filter Element.....	4-14
Float Control.....	4-20
G	
Gage,	
Differential Pressure.....	4-15
Sight	4-16
Grounding.....	4-21

INDEX (cont)

Subject	INDEX (cont)	Paragraph
	H	
Hand Receipt Manual		1-6
	I	
Inspection		4-6
Installation		4-7
	J, K	
	L	
Location and Description of Major Components		1-8
Lubrication Instructions		3-1
	M	
Maintenance Forms, Records and Reports		1-2
Maintenance		3-4, 4-12
Unit		4-1
Manual Drain Valve		4-18
	N	
	O	
Operating Procedure		2-10
Operation In		
Dusty or Sandy Area		2-14
Extreme Cold		2-12
Extreme Heat		2-13
Rainy or Humid Conditions		2-15
Operation Under Unusual Conditions		2-12
Operation Under Usual Conditions		2-9
Operator Maintenance		3-4
Operator Preventive Maintenance Checks and Services (PMCS)		2-3

INDEX (cont)

Subject Paragraph

P

Preparation for Storage or Shipment..... 1-5
 Pressure Relief Valve 4-13
 Preventive Maintenance Checks and Services
 Operator..... 2-3
 Unit 4-9
 Principles of Operation 1-11

Q

R

Repair Parts; Special Tools; and Support Equipment..... 4-2, 4-3
 Reporting Equipment Improvement Recommendations (EIR) 1-3

S

Safety, Care and Handling..... 1-10
 Service Upon Receipt..... 4-4
 Sight Gage 4-16
 Starting Procedure 2-9
 Stopping Procedure 2-11

T

Troubleshooting Procedures
 Operator..... 3-3
 Unit 4-11

U

Unit Maintenance 4-12
 Unit Preventive Maintenance Checks and Services (PMCS)..... 4-9
 Unit Troubleshooting 4-11
 Unloading 4-4
 Unpacking 4-5

INDEX (cont)

Subject Paragraph

V

Valve,

Automatic Drain	4-19
Float Control	4-20
Manual Drain.....	4-18
Pressure Relief	4-17

W, X, Y, Z

By Order of the Secretary of the Army:

CARL E. VUONO
General, United States Army
Chief of Staff

Official:

THOMAS F. SIKORA
Brigadier General, United States Army
The Adjutant General

DISTRIBUTION:

To be distributed in accordance with DA Form 12-25E, (qty rqr bl no. 0799).

* U.S. GOVERNMENT PRINTING OFFICE: 1991 554-123/20272

RECOMMENDED CHANGES TO EQUIPMENT TECHNICAL PUBLICATIONS

 <p style="font-size: small; margin: 0;"><i>THEN...JOT DOWN THE DOPE ABOUT IT ON THIS FORM. CAREFULLY TEAR IT OUT, FOLD IT AND DROP IT IN THE MAIL.</i></p>		SOMETHING WRONG WITH PUBLICATION	
		FROM: (PRINT YOUR UNIT'S COMPLETE ADDRESS)	
		DATE SENT	
PUBLICATION NUMBER		PUBLICATION DATE	PUBLICATION TITLE
IN THIS SPACE, TELL WHAT IS WRONG AND WHAT SHOULD BE DONE ABOUT IT.			
BE EXACT PIN-POINT WHERE IT IS			
PAGE NO.	PARA-GRAPH	FIGURE NO.	TABLE NO.
PRINTED NAME, GRADE OR TITLE AND TELEPHONE NUMBER		SIGN HERE	

The Metric System and Equivalents

Linear Measure

1 centimeter = 10 millimeters = .39 inch
 1 decimeter = 10 centimeters = 3.94 inches
 1 meter = 10 decimeters = 39.37 inches
 1 decameter = 10 meters = 32.8 feet
 1 hectometer = 10 decameters = 328.08 feet
 1 kilometer = 10 hectometers = 3, 280.8 feet

Weights

1 centigram = 10 milligrams = .15 grain
 1 decigram = 10 centigrams = 1.54 grains
 1 gram = 10 decigram = .035 ounce
 1 decagram = 10 grams = .35 ounce
 1 hectogram = 10 decagrams = 3.52 ounces
 1 kilogram = 10 hectograms = 2.2 pounds
 1 quintal = 100 kilograms = 220.46 pounds
 1 metric ton = 10 quintals = 1.1 short tons

Liquid Measure

1 centiliter = 10 milliliters = .34 fl. ounce
 1 deciliter = 10 centiliters = 3.38 fl. ounces
 1 liter = 10 deciliters = 33.81 fl. ounces
 1 deciliter = 10 liters = 2.64 gallons
 1 hectoliter = 10 dekaliters = 26.42 gallons
 1 kiloliter = 10 hectoliters = 264.18 gallons

Square Measure

1 sq. centimeter = 100 sq. millimeters = .155 sq. inch
 1 sq. decimeter = 100 sq. centimeters = 15.5 sq. inches
 1 sq. meter (centare) = 100 sq. decimeters = 10.76 sq. feet
 1 sq. decameter (are) = 100 sq. meters = 1, 076.4 sq. feet
 1 sq. hectometer (hectare) = 100 sq. decameters = 2.47 acres
 1 sq. kilometer = 100 sq. hectometers = .386 sq. mile

Cubic Measure

1 cu. centimeter = 1000 cu. millimeters = .06 cu. inch
 1 cu. decimeter = 1000 cu. centimeters = 61.02 cu. inches
 1 cu. meter = 1000 cu. decimeters = 35.31 cu. feet

Approximate Conversion Factors

<i>To change</i>	<i>To</i>	<i>Multiply by</i>	<i>To change</i>	<i>To</i>	<i>Multiply by</i>
inches	centimeters	2.540	ounce-inches	Newton-meters	.007062
feet	meters	.305	centimeters	inches	.394
yards	meters	.914	meters	feet	3.280
miles	kilometers	1.609	meters	yards	1.094
square inches	square centimeters	6.451	kilometers	miles	.621
square feet	square meters	.093	square centimeters	square inches	.155
square yards	square meters	.836	square meters	square feet	10.764
square miles	square kilometers	2.590	square meters	square yards	1.196
acres	square hectometers	.405	square kilometers	square miles	.386
cubic feet	cubic meters	.028	square hectometers	acres	2.471
cubic yards	cubic meters	.765	cubic meters	cubic feet	35.315
fluid ounces	milliliters	29, 573	cubic meters	cubic yards	1.308
pints	liters	.473	milliliters	fluid ounces	.034
quarts	liters	.946	liters	pints	2.113
gallons	liters	3.785	liters	quarts	1.057
ounces	grams	28.349	liters	gallons	.264
pounds	kilograms	.454	grams	ounces	.035
short tons	metric tons	.907	kilograms	pounds	2.205
pound-feet	Newton-meters	1.356	metric tons	short tons	1.102
pound-inches	Newton-meters	.11296			

Temperature (Exact)

°F	Fahrenheit temperature	5/9 (after subtracting 32)	Celsius temperature	°C
----	------------------------	----------------------------	---------------------	----

